

ISO 5173:2023(E)

2023-01

ISO TC 44/SC 5/AHG 1

Secretariat: AFNOR

Destructive tests on welds in metallic materials — Bend tests

Essais destructifs des soudures sur matériaux métalliques — Essais de pliage

© ISO 2023

All rights reserved. Unless otherwise specified, or required in the context of its implementation, no part of this publication may be reproduced or utilized otherwise in any form or by any means, electronic or mechanical, including photocopying, or posting on the internet or an intranet, without prior written permission. Permission can be requested from either ISO at the address below or ISO's member body in the country of the requester.

ISO copyright office

CP 401 • Ch. de Blandonnet 8

CH-1214 Vernier, Geneva

Phone: +41 22 749 01 11

Fax: +41 22 749 09 47

Email: copyright@iso.org

Website: www.iso.org

Published in Switzerland

Contents

Foreword	v
1 Scope	1
2 Normative references	1
3 Terms and definitions	1
Figure 1 — Transverse face bend test specimen for a butt weld (TFBB)	2
Figure 2 — Transverse root bend test specimen for a butt weld (TRBB)	3
Figure 3 — Transverse side bend test specimen for a butt weld (TSBB)	3
Figure 4 — Longitudinal face/root bend test specimen for a butt weld (LFBB and LRBB)	4
Figure 5 — Face bend test specimen for cladding without a butt weld (FBC)	5
Figure 6 — Side bend test specimen for cladding without a butt weld (SBC)	6
Figure 7 — Face bend test specimen for cladding with a butt weld (FBCB)	6
Figure 8 — Side bend test specimen for cladding with a butt weld (SBCB)	7
4 Symbols and abbreviated terms	7
Table 1 — Symbols	7
5 Principle	8
6 Preparation of test specimens	8
6.1 General	8
6.2 Location	8
6.3 Marking	8
6.4 Heat treatment and/or ageing	9
6.5 Extraction	9
6.6 Specimen size	9
6.6.1 Transverse root and face bend tests of a butt weld (TRBB and TFBB)	9
6.6.2 Transverse side bend tests of a butt weld (TSBB)	9
6.6.3 Longitudinal bend tests of a butt weld (LFBB and LRBB)	9
6.6.4 Face bend tests of cladding material without a butt weld (FBC)	9
6.6.5 Side bend tests of cladding material without a butt weld (SBC)	10
6.6.6 Transverse face bend tests of cladding material with a butt weld (FBCB)	10
Figure 9 — Root and face bend test specimens for a butt weld (TFBB, TRBB, LFBB, LRBB and FBCB)	10
Figure 10 — Side bend test specimens for a butt weld (TSBB and SBCB)	11
6.6.7 Side bend tests of cladding material with a butt weld (SBCB)	11
6.6.8 Dimensions	11
6.6.9 Surface preparation	12
7 Conditions of testing	12
7.1 Etching	12
7.2 Testing	12
7.2.1 General	12
7.2.2 Testing with a former	12

Figure 11 — Transverse face or root bend test	14
Figure 12 — Transverse side bend test	14
Figure 13 — Longitudinal bend test.....	15
Figure 14 — Example of shape of U-type jig for bend test	16
7.2.3 Testing with a roller	16
Figure 15 — Method of bend testing using a roller	17
7.2.4 Bend testing with backing plate.....	17
Figure 16 — Bending test with backing plate.....	18
Figure 17 — Backing plate geometry	19
7.3 Diameter of former and roller	19
7.3.1 Steel, nickel and nickel alloys	19
7.3.2 Aluminium and its alloys	19
7.4 Distance between and radius of parallel rollers.....	19
7.5 Bending angle.....	20
7.6 Bending elongation	20
8 Test results.....	20
9 Test report.....	20
Annex A (informative) Example of a test report	22
Table A.1 —Bend test in accordance with ISO 5173:2023	22
Bibliography	23

Foreword

ISO (the International Organization for Standardization) is a worldwide federation of national standards bodies (ISO member bodies). The work of preparing International Standards is normally carried out through ISO technical committees. Each member body interested in a subject for which a technical committee has been established has the right to be represented on that committee. International organizations, governmental and non-governmental, in liaison with ISO, also take part in the work. ISO collaborates closely with the International Electrotechnical Commission (IEC) on all matters of electrotechnical standardization.

The procedures used to develop this document and those intended for its further maintenance are described in the ISO/IEC Directives, Part 1. In particular, the different approval criteria needed for the different types of ISO documents should be noted. This document was drafted in accordance with the editorial rules of the ISO/IEC Directives, Part 2 (see www.iso.org/directives).

Attention is drawn to the possibility that some of the elements of this document may be the subject of patent rights. ISO shall not be held responsible for identifying any or all such patent rights. Details of any patent rights identified during the development of the document will be in the Introduction and/or on the ISO list of patent declarations received (see www.iso.org/patents).

Any trade name used in this document is information given for the convenience of users and does not constitute an endorsement.

For an explanation of the voluntary nature of standards, the meaning of ISO specific terms and expressions related to conformity assessment, as well as information about ISO's adherence to the World Trade Organization (WTO) principles in the Technical Barriers to Trade (TBT), see www.iso.org/iso/foreword.html.

This document was prepared by Technical Committee ISO/TC 44, *Welding and allied processes*, Subcommittee SC 5, *Testing and inspection of welds*, in collaboration with the European Committee for Standardization (CEN) Technical Committee CEN/TC 121, *Welding and allied processes*, in accordance with the Agreement on technical cooperation between ISO and CEN (Vienna Agreement).

This fourth edition cancels and replaces the third edition (ISO 5173:2009) which has been technically revised. It also incorporates the Amendment ISO 5173:2009/Amd 1:2011.

The main changes are as follows:

- scope has been updated to introduce guided transverse bend tests with a roller and longitudinal bend tests as alternative methods of testing for heterogeneous assemblies;
- in Clause 4, the testing temperature has been removed;
- Subclause 7.2.2 has been modified accordingly;
- figures have been corrected;
- document has been aligned with the latest ISO/IEC Directives, Part 2.

Any feedback or questions on this document should be directed to the user's national standards body. A complete listing of these bodies can be found at www.iso.org/members.html. Official interpretations of

ISO 5173:2023(E)

ISO/TC 44 documents, where they exist, are available from this page:
<https://committee.iso.org/sites/tc44/home/interpretation.html>.

Destructive tests on welds in metallic materials — Bend tests

1 Scope

This document specifies a method for making transverse root, face and side bend tests on test specimens taken from butt welds, butt welds with cladding (subdivided into welds in clad plates and clad welds) and cladding without butt welds, in order to reveal imperfections on or near the surface of the test specimen which is under tension during bend testing and/or assess ductility. It also gives the dimensions of the test specimen.

In addition, this document specifies methods to be used instead of transverse bend tests with a former for welded joints when base materials, heat affected zones and/or weld metal have a significant difference in their physical and mechanical properties in relation to bending.

This document applies to metallic materials in all forms of product with welded joints made by any welding process.

2 Normative references

There are no normative references in this document.

3 Terms and definitions

For the purposes of this document, the following terms and definitions apply.

ISO and IEC maintain terminology databases for use in standardization at the following addresses:

- ISO Online browsing platform: available at <https://www.iso.org/obp>
- IEC Electropedia: available at <https://www.electropedia.org/>

3.1

transverse face bend test specimen for a butt weld

TFBB

transverse butt weld specimen where the face is in tension

Note 1 to entry: See [Figure 1](#).

Dimensions in millimetres

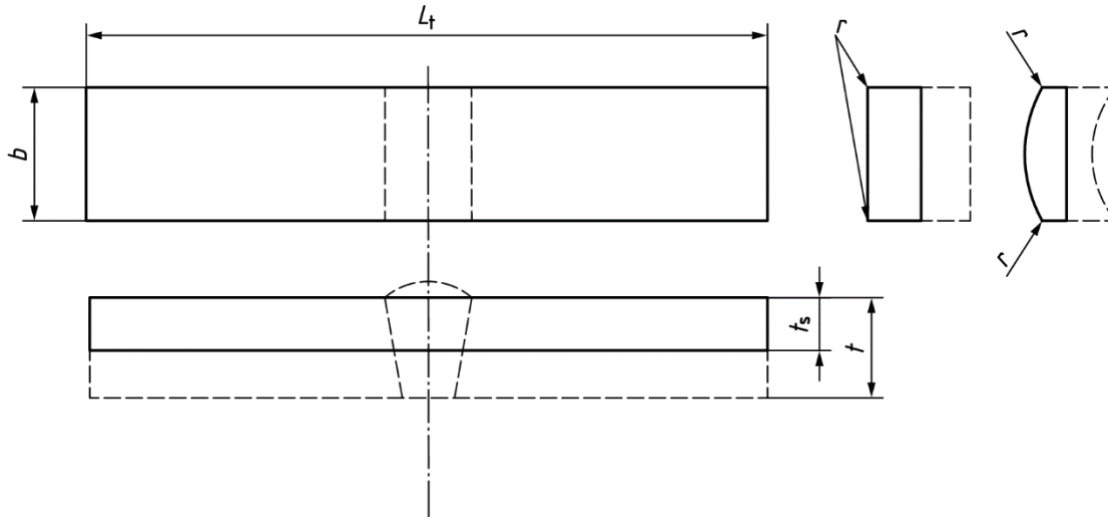

Key

- b width of the test specimen
- L_t total length of the test specimen
- r radius of the test specimen edges
- t thickness of the test piece
- t_s thickness of the test specimen

Figure 1 — Transverse face bend test specimen for a butt weld (TFBB)

3.2 transverse root bend test specimen for a butt weld TRBB

transverse butt weld specimen where the root is in tension

Note 1 to entry: See [Figure 2](#).

Dimensions in millimetres

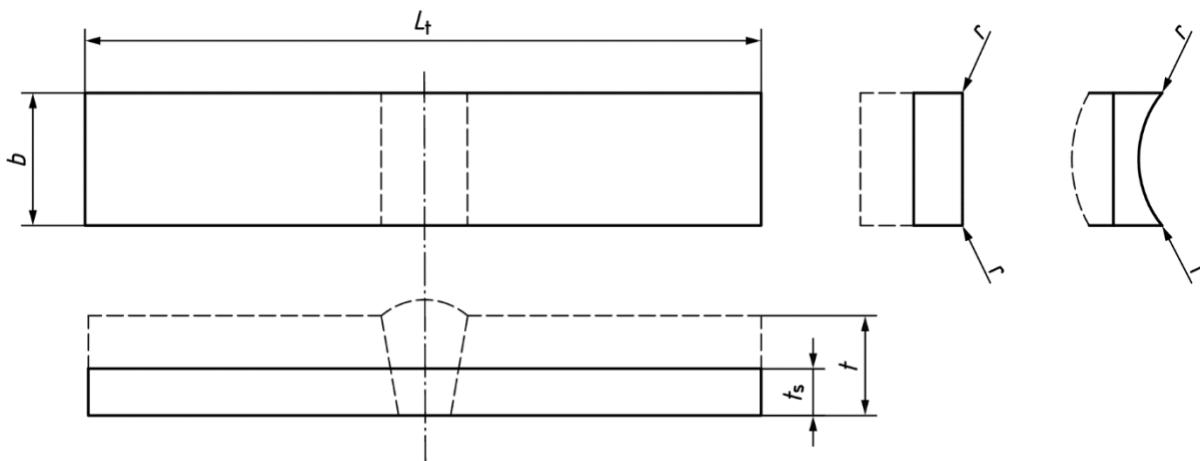

Key

- b width of the test specimen

- L_t total length of the test specimen
 r radius of the test specimen edges
 t thickness of the test piece
 t_s thickness of the test specimen

Figure 2 — Transverse root bend test specimen for a butt weld (TRBB)

**3.3
transverse side bend test specimen for a butt weld
TSBB**

specimen where the surface in tension is a cross-section of the weld

Note 1 to entry: See [Figure 3](#).

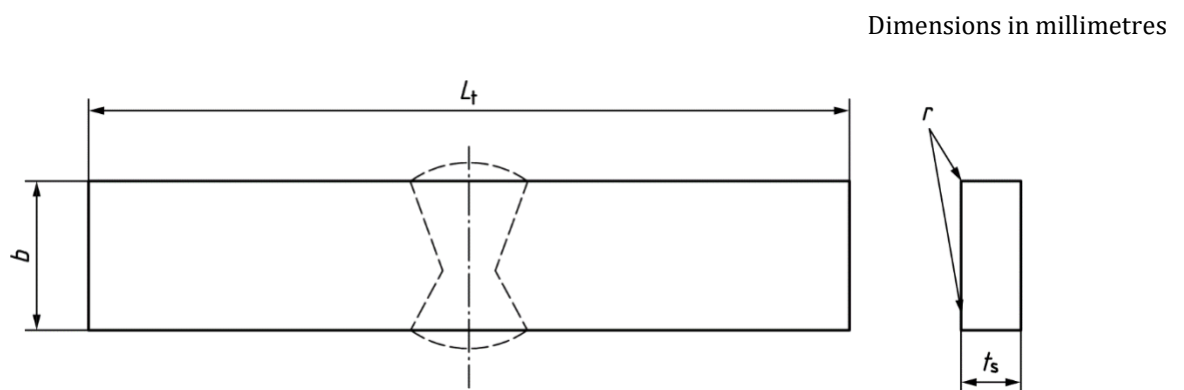

Key

- b width of the test specimen
 L_t total length of the test specimen
 r radius of the test specimen edges
 t_s thickness of the test specimen

Figure 3 — Transverse side bend test specimen for a butt weld (TSBB)

**3.4
longitudinal face bend test specimen for a butt weld
LFBB**

specimen where the direction is parallel to the butt weld direction and where the face is in tension

Note 1 to entry: See [Figure 4](#)

Dimensions in millimetres

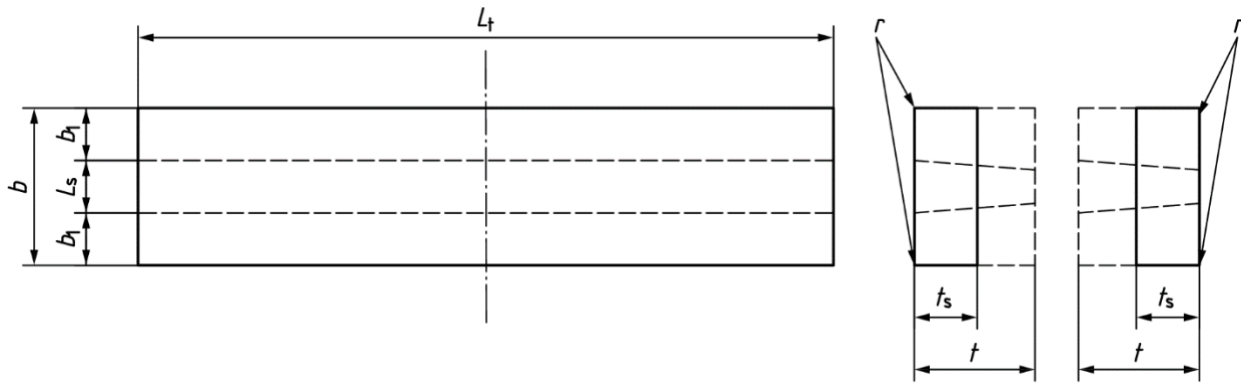

Key

- b width of the test specimen
- L_s maximum width after machining
- L_t total length of the test specimen
- r radius of the test specimen edges
- t thickness of the test piece
- t_s thickness of the test specimen
- b_1 width of outside fusion line

Figure 4 — Longitudinal face/root bend test specimen for a butt weld (LFBB and LRBB)

3.5 longitudinal root bend test specimen for a butt weld LRBB

specimen where the direction is parallel to the butt weld direction and where the root is in tension

Note 1 to entry: See Figure 4.

3.6 face bend test specimen for cladding without a butt weld FBC

specimen for which the cladding is in tension, applicable to both transverse and longitudinal specimens

Note 1 to entry: See Figure 5.

Dimensions in millimetres

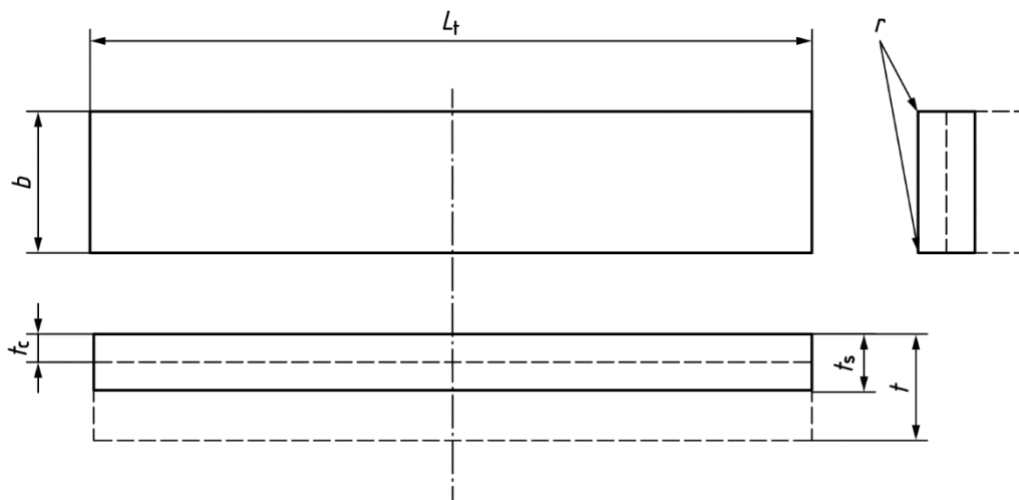

Key

- b width of the test specimen
- L_t total length of the test specimen
- r radius of the test specimen edges
- t thickness of the test piece
- t_s thickness of the test specimen
- t_c thickness of the cladding

Figure 5 — Face bend test specimen for cladding without a butt weld (FBC)

3.7

side bend test specimen for cladding without a butt weld

SBC

specimen for which the cross-section of the cladding overlay is in tension, applicable to both transverse and longitudinal specimens

Note 1 to entry: See [Figure 6](#).

Dimensions in millimetres

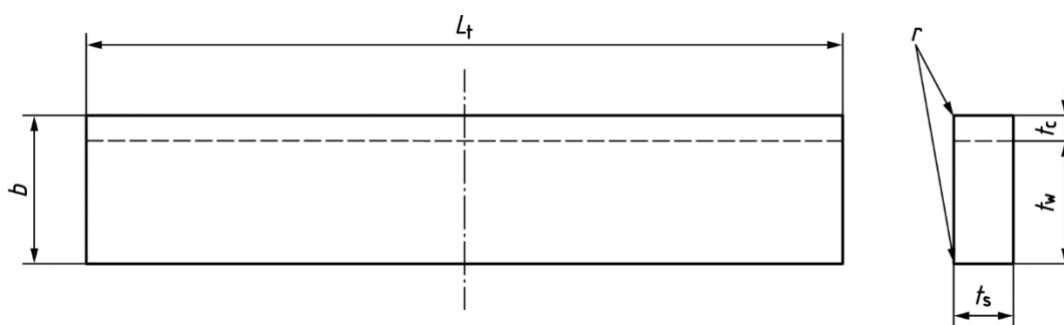

Key

- b width of the test specimen
- L_t total length of the test specimen
- r radius of the test specimen edges

- t thickness of the test piece
- t_s thickness of the test specimen
- t_w thickness of parent material under cladding
- t_c thickness of the cladding

Figure 6 — Side bend test specimen for cladding without a butt weld (SBC)

3.8
face bend test specimen for cladding with a butt weld
FBCB

specimen containing a butt weld where the cladding is in tension

Note 1 to entry: See [Figure 7](#).

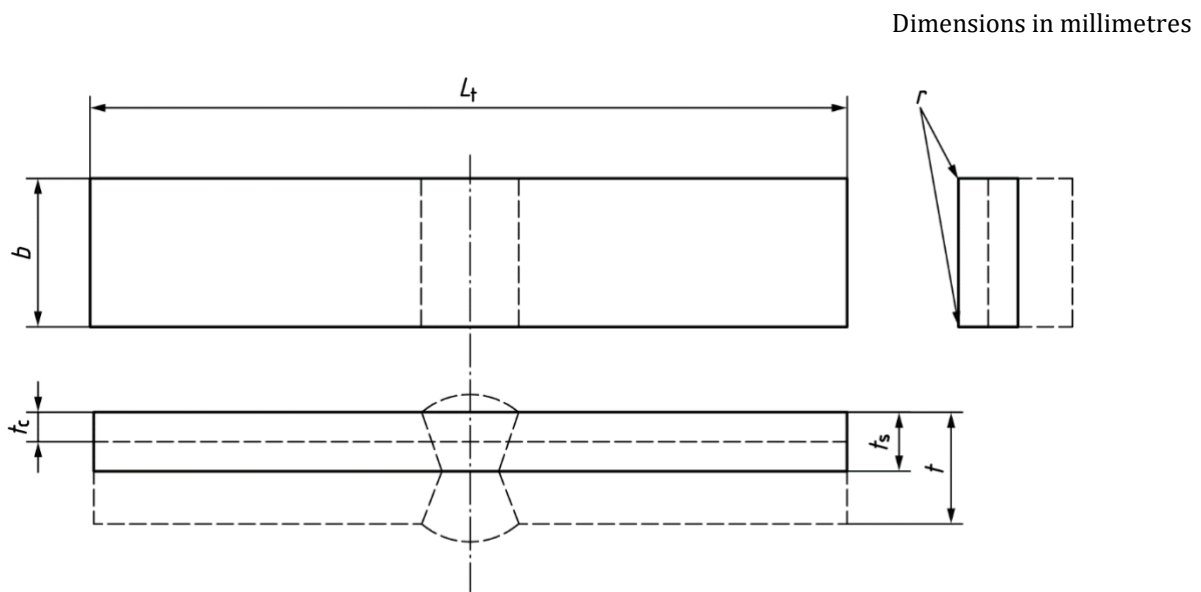

Key

- b width of the test specimen
- L_t total length of the test specimen
- r radius of the test specimen edges
- t thickness of the test piece
- t_s thickness of the test specimen
- t_c thickness of the cladding

Figure 7 — Face bend test specimen for cladding with a butt weld (FBCB)

3.9
side bend test specimen for cladding with a butt weld
SBCB

specimen containing a butt weld where the cross-section of the cladding is in tension

Note 1 to entry: See [Figure 8](#).

Dimensions in millimetres

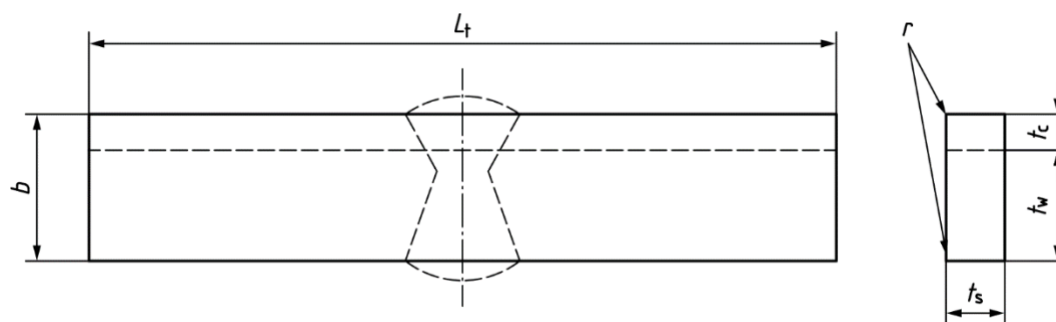

Key

- b width of the test specimen
- L_t total length of the test specimen
- r radius of the test specimen edges
- t_s thickness of the test specimen
- t_w thickness of parent material under cladding
- t_c thickness of the cladding

Figure 8 — Side bend test specimen for cladding with a butt weld (SBCB)

4 Symbols and abbreviated terms

Table 1 — Symbols

Symbol	Designation	Unit
A	minimum percentage elongation after fracture required by the parent material specification	%
b	width of the test specimen	mm
b_1	width of outside fusion line	mm
d	diameter of the former or the inner roller	mm
D	outside diameter of the pipe ^a	mm
l	distance between the rollers	mm
L_b	length of additional backing plate	mm
L_f	initial distance between contact of the roller and the centre line of the weld	mm
L_0	original gauge length	mm
L_S	maximum width of the weld after machining	mm
L_t	total length of the test specimen	mm
r	radius of the test specimen edges	mm
r_P	plunger radius	mm
r_D	die radius	mm

R	radius of the rollers	mm
t	thickness of the test piece	mm
t_c	thickness of the cladding	mm
t_b	thickness of additional backing plate	mm
t_s	thickness of the test specimen	mm
t_w	thickness of parent material under cladding	mm
α	bending angle	°
^a The term “pipe”, alone or in combination, is used to mean “pipe”, “tube” or “hollow section (without rectangular cross section)”.		

5 Principle

Submitting a test specimen, taken transversely or longitudinally from a welded joint, to plastic deformation by bending it, without reversing the bending direction, in such a way that one of the surfaces or cross-sections of the welded joint is in tension.

The temperature at which the tests are carried out shall be recorded (see Clause 9).

The testing speed should be constant and recorded when known (see Clause 9).

The test shall be made in accordance with one of the methods described in Clause 7.

6 Preparation of test specimens

6.1 General

Specimens shall be prepared in such a manner that the preparation does not affect either the parent material or the weld metal.

6.2 Location

For transverse bend testing of butt welds, the test specimen shall be taken transversely from the welded joint of the manufactured product or from the welded test piece in such a way that after machining the weld axis will remain in the centre of the test specimen or at a suitable position for testing.

For longitudinal bend testing of butt welds, the test specimen shall be taken longitudinally from the welded joint of the manufactured product or from the welded test piece.

The location and orientation of bend test specimens of cladding material shall be specified by the application standard or by agreement between the contracting parties.

6.3 Marking

Each test piece shall be marked to identify its exact location in the manufactured product or in the joint from which it has been removed.

If required by the relevant application standard, the direction of working (e.g. rolling or extrusion) shall be marked.

Each test specimen shall be marked to identify its exact location in the test piece from which it has been removed.

6.4 Heat treatment and/or ageing

No heat treatment shall be applied to the welded joint or to the test specimen unless it is specified or permitted by the relevant application standard dealing with the welded joint to be tested. Details of any heat treatment shall be recorded in the test report. If natural ageing of aluminium alloys takes place, the time between welding and testing shall be recorded.

6.5 Extraction

The mechanical or thermal processes used to extract the test specimen shall not change the properties of the test specimen in any way. Any material that is affected by thermal cutting or shearing shall be mechanically removed.

6.6 Specimen size

6.6.1 Transverse root and face bend tests of a butt weld (TRBB and TFBB)

For transverse root and face bend tests, the test specimen thickness, t_s , shall be equal to the thickness of the parent material adjacent to the welded joint up to a maximum thickness of 30 mm. If the test piece thickness, t , is greater than 10 mm, the test specimen thickness, t_s , may be machined or otherwise mechanically finished from one side to a thickness equal to $(10 \pm 0,5)$ mm as indicated in [Figures 1 and 2](#). The face or root of the weld shall be in tension when the specimen is bent.

When a relevant application standard requires testing of a full thickness > 10 mm, several test specimens may be taken in order to cover the full thickness of the joint as indicated in [Figure 9](#).

In such cases, the location of the test specimen in the welded joint thickness shall be identified.

6.6.2 Transverse side bend tests of a butt weld (TSBB)

For side bend tests, the test specimen width, b , shall be equal to the thickness of the parent material of the welded joint. The specimen shall have a thickness, t_s , equal to $(10 \pm 0,5)$ mm as indicated in [Figure 3](#), unless otherwise specified in the relevant application standard.

When the joint thickness exceeds 40 mm, the specimen may be split in the plane of the test piece thickness as shown in [Figure 10](#). In these cases, the location of the test specimen in the welded joint thickness shall be identified.

6.6.3 Longitudinal bend tests of a butt weld (LFBB and LRBB)

For longitudinal bend tests, the test specimen thickness, t_s , shall be equal to the thickness of the parent material near the welded joint, but should not exceed 10 mm. If the test piece thickness, t , is greater than 10 mm, the test specimen thickness, t_s , may be machined or otherwise mechanically finished from one side to a thickness equal to $(10 \pm 0,5)$ mm as indicated in [Figure 4](#). The face or root of the weld shall be in tension when the specimen is bent.

When a relevant application standard requires testing of a full thickness > 10 mm, several test specimens may be taken in order to cover the full thickness of the joint as indicated in [Figure 9](#).

6.6.4 Face bend tests of cladding material without a butt weld (FBC)

For face bend tests, the test specimen thickness, t_s , shall be equal to the thickness of the base material, t_w , plus the thickness of the cladding, t_c , but should not exceed 10 mm. If the test piece thickness, t , is greater than 10 mm, the test specimen thickness, t_s , may be machined or otherwise mechanically finished from the base metal to a thickness equal to $(10 \pm 0,5)$ mm as indicated in [Figure 5](#).

When the thickness of the parent material plus cladding is greater than t_s , parent material may be removed to obtain a test specimen thickness, t_s .

6.6.5 Side bend tests of cladding material without a butt weld (SBC)

For side bend tests, the test specimen width, b , shall be equal to the thickness of the base material plus the thickness of the cladding, up to a maximum of 40 mm. The specimen shall have a thickness, t_s , equal to $(10 \pm 0,5)$ mm as indicated in Figure 6, unless otherwise specified in the relevant application standard.

When the thickness of the parent material plus cladding exceeds 40 mm, parent material may be removed to obtain a test specimen thickness, t_s .

6.6.6 Transverse face bend tests of cladding material with a butt weld (FBCB)

For transverse face bend tests of cladding with a butt weld, the test specimen thickness, t_s , shall be equal to the thickness of the parent material, t_w , plus the thickness of the cladding, t_c , but should not exceed 10 mm. If the test piece thickness, t , is greater than 10 mm, the test specimen thickness, t_s , may be equal to $(10 \pm 0,5)$ mm as indicated in Figure 7, if cladding thickness permits.

In such a case, the location of the weld shall remain in the middle of the test specimen or at a suitable position for testing. When the test concerns the complete joint incorporating both the butt joint and the cladding, and when the thickness of the joint is greater than t_s , several specimens may be taken as described in 6.6.1 and Figure 9.

When the purpose of the test is to examine the cladding only and when the thickness of the parent material plus cladding is greater than t_s , no further tests on the parent material are required.

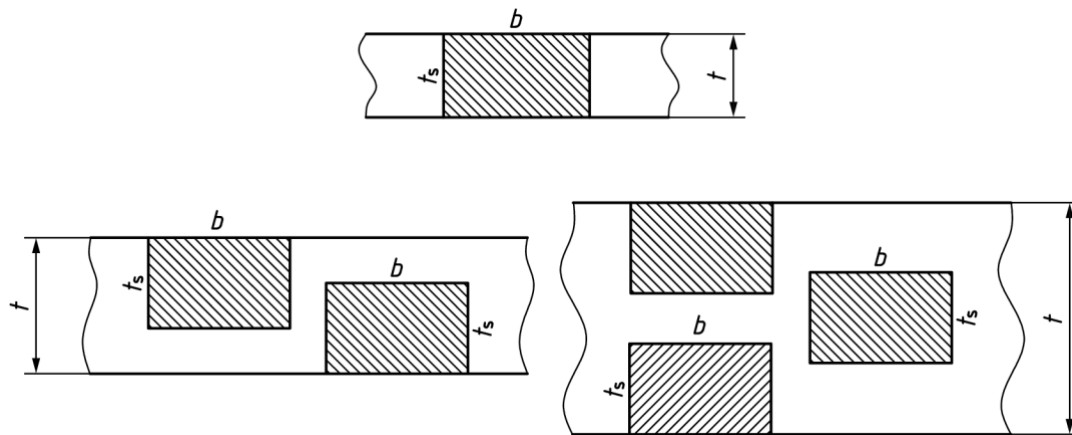

Figure 9— Root and face bend test specimens for a butt weld (TFBB, TRBB, LFBB, LRBB and FBCB)

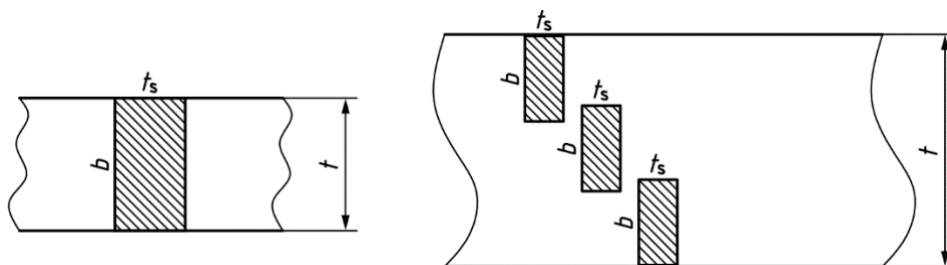

Figure 10 — Side bend test specimens for a butt weld (TSBB and SBCB)

6.6.7 Side bend tests of cladding material with a butt weld (SBCB)

For side bend tests of cladding with a butt weld, the test specimen width, b , shall be equal to the test piece thickness, t (thickness of the parent material, t_w , plus cladding, t_c), up to a maximum of 40 mm. The specimen shall have a thickness, t_s , equal to $(10 \pm 0,5)$ mm as indicated in Figure 8, unless otherwise specified in the relevant application standard.

When the test piece thickness, t , exceeds 40 mm, the specimen may be split in the plane of the test piece thickness as described in 6.6.2 and Figure 10.

6.6.8 Dimensions

6.6.8.1 Length

The total length, L_t , of test specimens shall conform to the value obtained with Formula (1):

$$L_t \geq l + 2R \quad (1)$$

6.6.8.2 Thickness

The thickness of test specimens, t_s , shall be in accordance with 6.6.1 to 6.6.7.

6.6.8.3 Width

a) Transverse root or face bend tests:

- 1) for plates: the width, b , of the test specimen shall be $4t_s$ or greater, unless otherwise specified in the relevant application standard;
- 2) for pipes, the width, b , of the test specimen shall be:
 - for pipes with diameter less than 25 mm, the width of the bend specimens may be that obtained by cutting the pipe into half or preferably quarter sections. These specimens are not required to have one surface machined flat as shown in Figures 1 and 2;
 - for outside pipe diameter from 25 mm to 50 mm: $b = t + 0,1 D$ (minimum width 8 mm);
 - for outside pipe diameter > 50 mm: $b = t + 0,05 D$ (minimum width 8 mm, but should not exceed 40 mm).

For an outside diameter, D , > 25 times the wall thickness of the pipe, the specimen may be taken as required for the flat plates.

- b) Transverse side bend tests: the width, b , of the test specimen should be equal to the thickness of the parent material near the welded joint, unless otherwise specified in the relevant application standard and/or by agreement between the contracting parties.
- c) Longitudinal bend tests: the width, b , of the test specimen shall be $b = L_s + 2 b_1$, where, $b_1 = 15$ mm, unless otherwise specified in the relevant application standard and/or by agreement between the contracting parties.

6.6.8.4 Edges

The edges of the test specimen on the face in tension shall be rounded by mechanical means to a radius, r , not exceeding $0,2 t_s$ to a maximum of 3 mm (see Figure 1 to Figure 8).

The rounding shall be made so that no transverse burrs, scratches or marks are formed which might adversely affect the test results.

However, testing a test piece, the edges of which have not been rounded, is acceptable, provided that the result is satisfactory.

6.6.9 Surface preparation

The final stages of preparation shall be obtained by machining or grinding, taking suitable precautions to avoid superficial strain hardening or excessive heating of the material. Within the length, l (see Figure 11 to Figure 13), the surface shall be free from scratches or notches transverse to the test specimen direction, except for undercuts, which shall not be removed unless required by the relevant application standard.

The surfaces of the test specimen shall be machined in such a way that, unless otherwise specified in the relevant application standard and/or by agreement between the contracting parties, all excess weld metal is removed. Unless otherwise specified, the penetration bead may be left intact inside pipes of small diameter on the opposite side of the former.

7 Conditions of testing

7.1 Etching

Before starting the bend test, the shape and the position of the fusion zone or fusion line may be established by lightly macro etching the surface of the test specimen to be tested in tension.

7.2 Testing

7.2.1 General

Testing of bend test specimens can be carried out in general with a former (see 7.2.2) or with a roller (see 7.2.3).

In case of welded joints, for which the parent materials, heat affected zones and/or weld metal have significant difference in their physical and mechanical properties in relation to bending, transverse and side bend testing of specimen TFBB, TRBB, TSBB, FBCB and SBCB with a former could result in non-uniform bending of the bend specimen. Thus, a localization of strains occurs and may result in premature failure, without the presence of any weld failure.

To avoid this phenomenon, alternative test methods like bend testing with a roller (see 7.2.3), bend testing with backing plate (see 7.2.4) or longitudinal bend testing are recommended.

The material dependent diameter of former or roller is defined in 7.3. All other geometrical conditions of test methods are defined in 7.2.2 to 7.2.4 and 7.4.

7.2.2 Testing with a former

The test shall be carried out by placing the test specimen on two supports consisting of parallel rollers (see Figure 11 to Figure 13) or U-type jig (see Figure 14).

The axis of weld shall be at the mid-point between the rollers respectively supporting points, except for longitudinal bend tests. The test specimen shall be bent by loading gradually and continuously in the middle of the span, on the axis of the weld, with a load applied by a former (three-point bending) perpendicular to the test specimen surface.

The radius of the plunger and die for the U-type jig shall be equal to the **Formulae (2) and (3)**:

$$r_p = d/2 \quad (2)$$

$$r_D = r_p + t_s + 2 \quad (3)$$

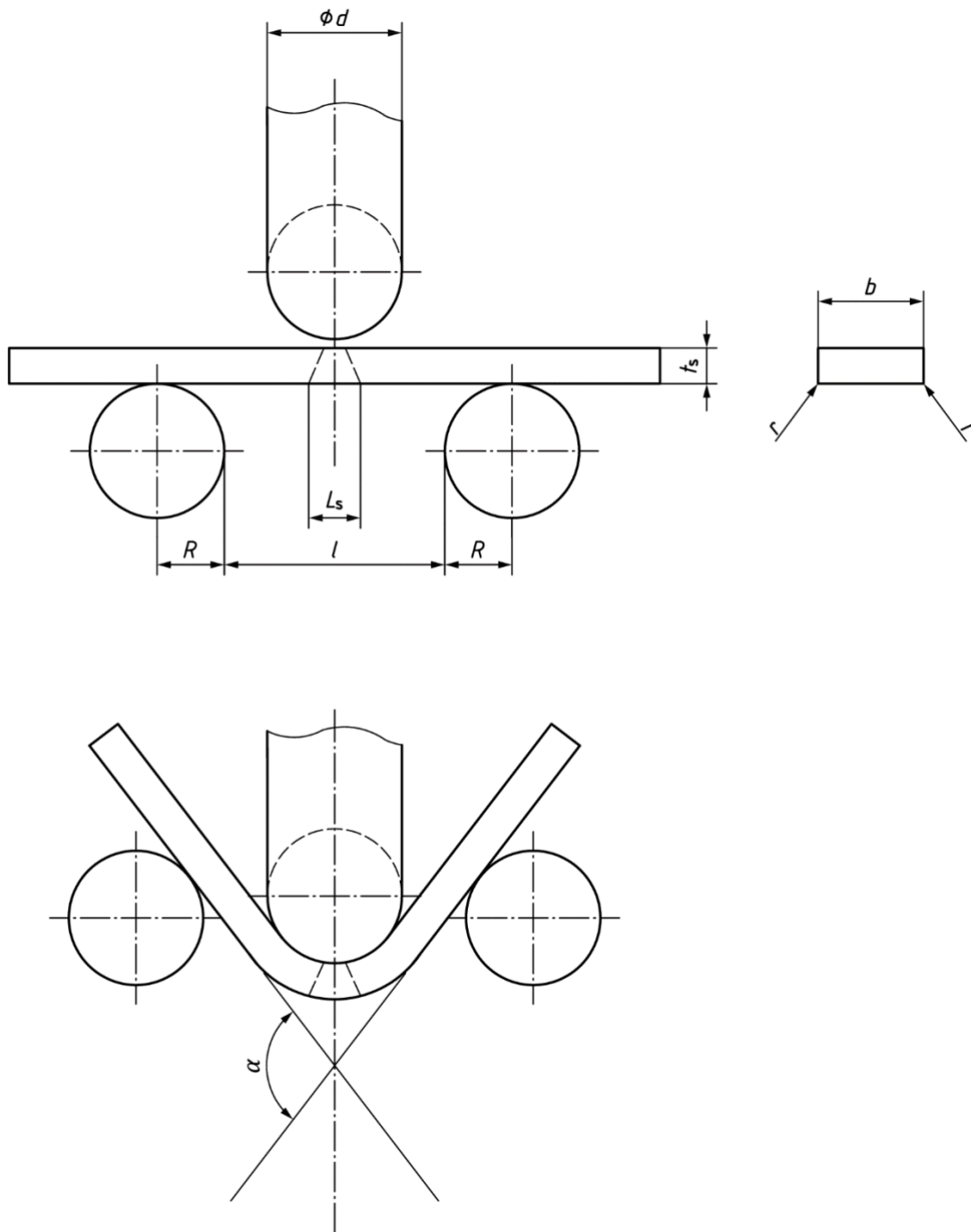

Figure 11 — Transverse face or root bend test

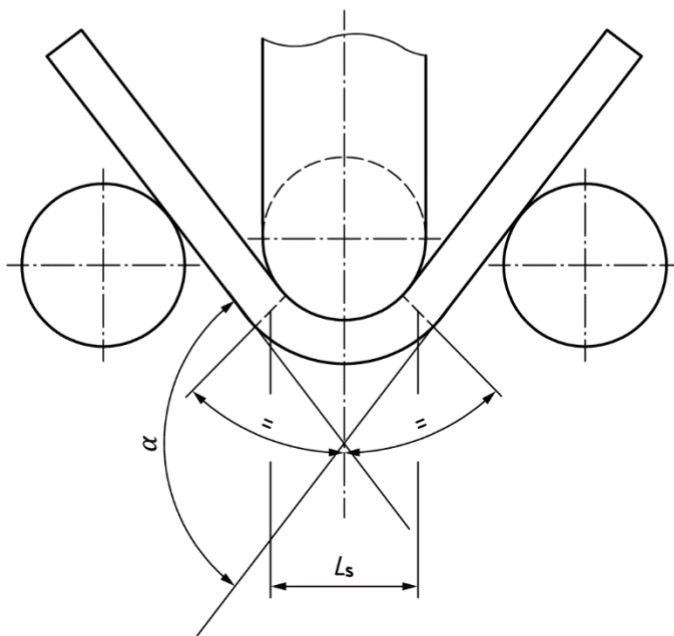
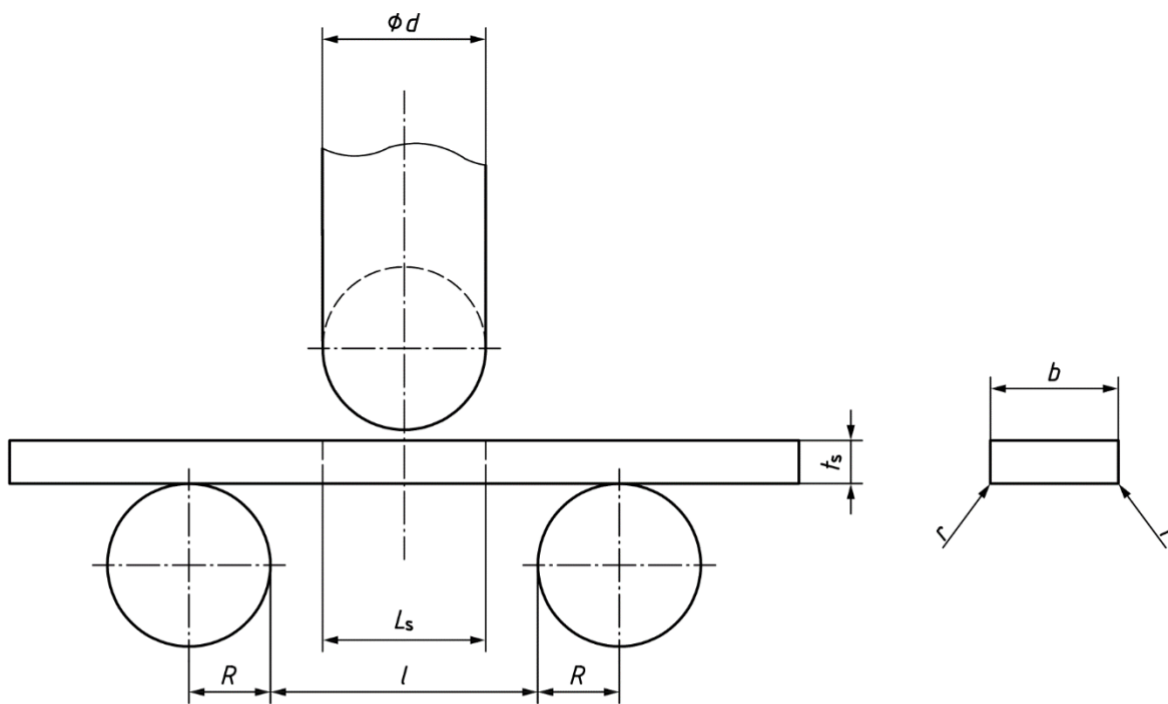

Figure 12 — Transverse side bend test

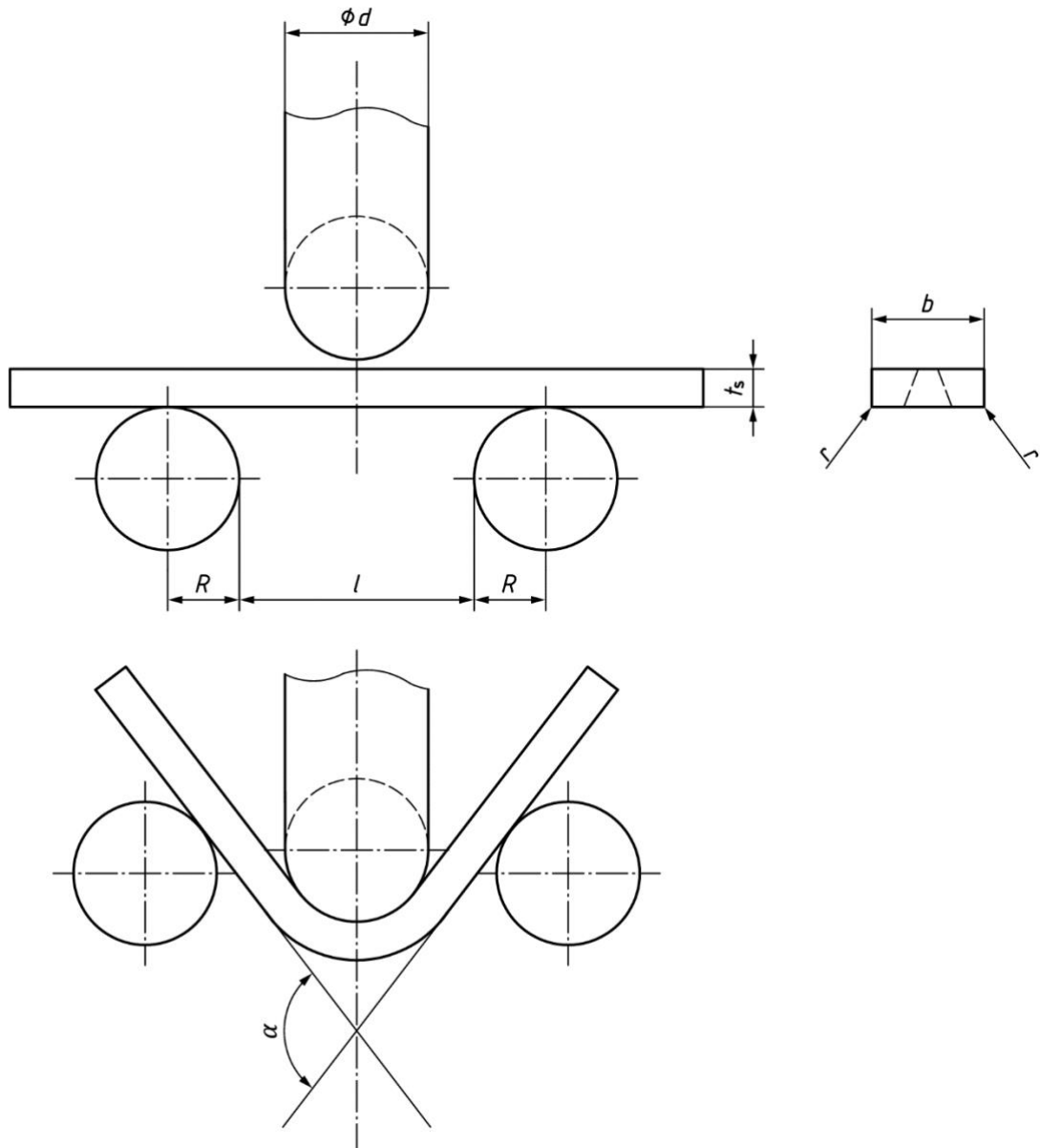
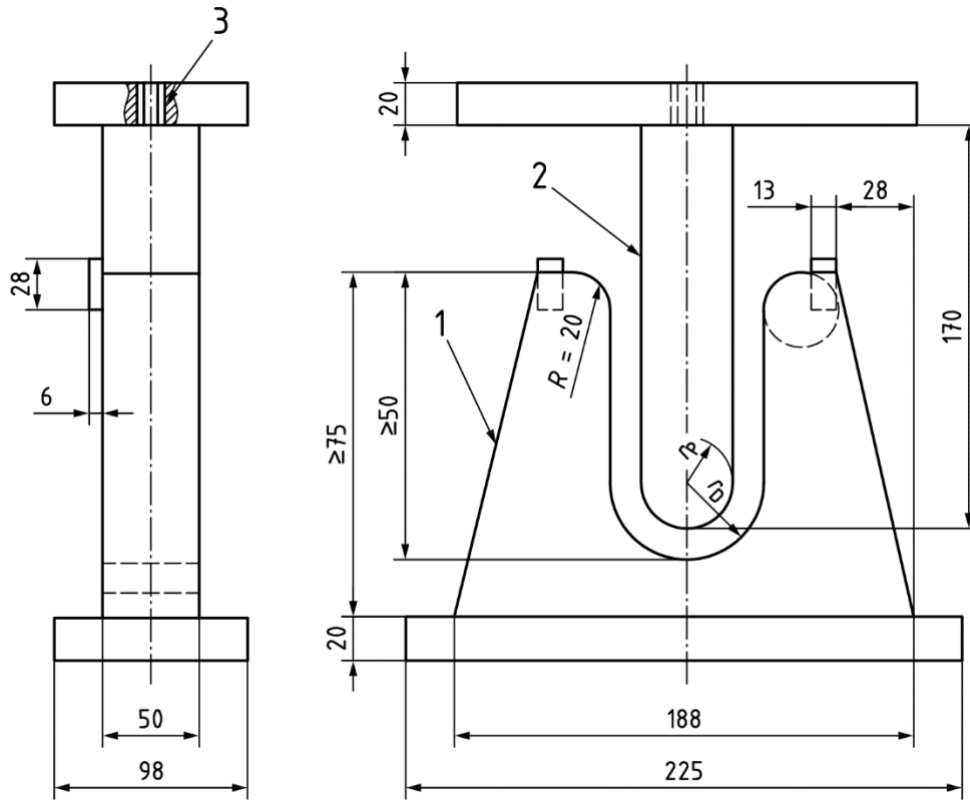

Figure 13 — Longitudinal bend test

Dimensions in millimetres



Key

- 1 die
- 2 plunger
- 3 tapped hole for attaching plunger to test machine

Figure 14 — Example of shape of U-type jig for bend test

7.2.3 Testing with a roller

See Figure 15. For Figure 15, the requirement $0,7 d < L_f < 0,9 d$ applies.

The test shall be carried out by firmly clamping one end of the test specimen in a testing device having a roller the axis of which is parallel to a former. The test specimen shall be bent by loading, gradually and continuously, by means of the rotation of the outer roller through an arc centred on the axis of the former.

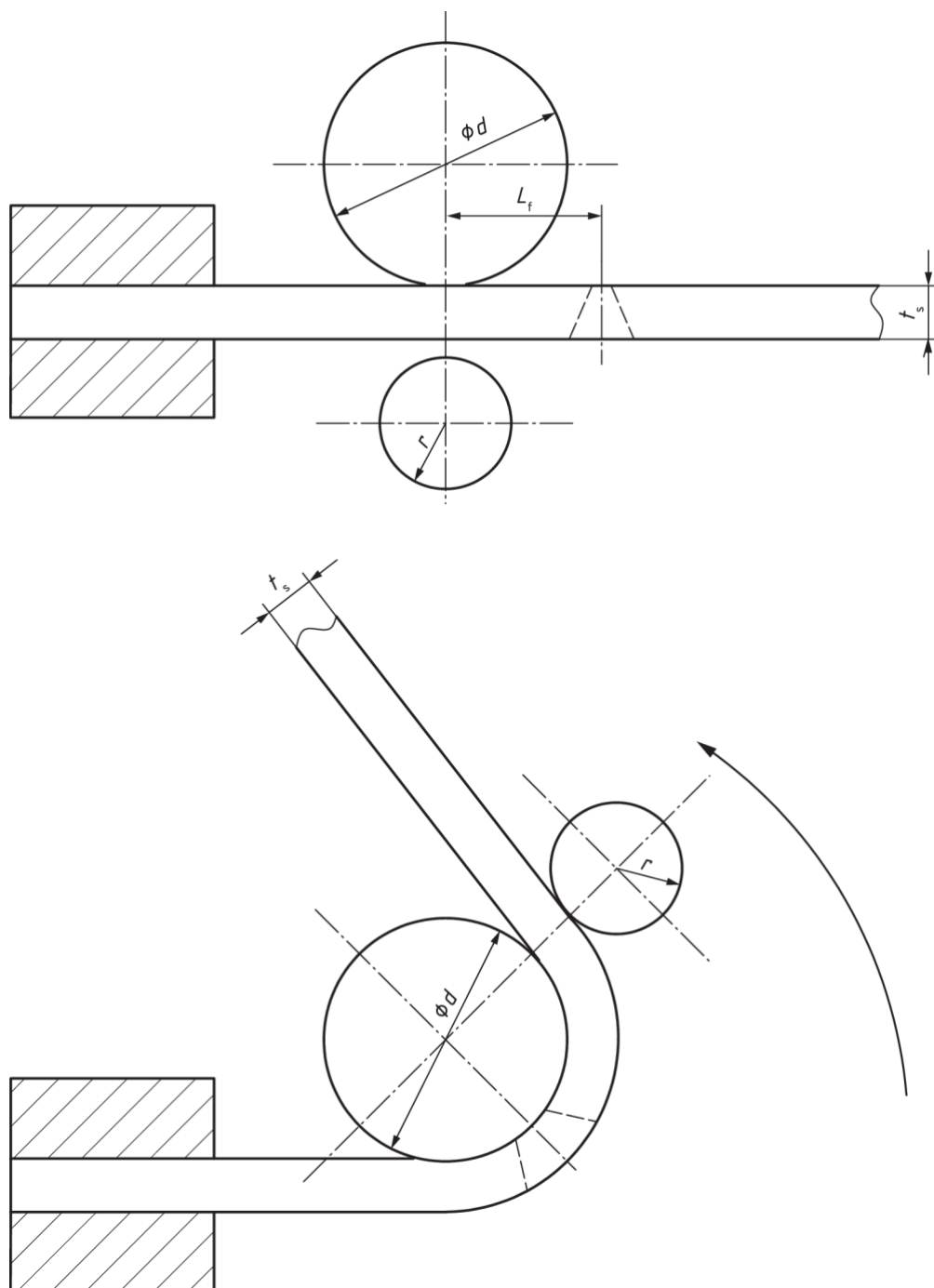

Figure 15 — Method of bend testing using a roller

7.2.4 Bend testing with backing plate

The test shall be carried out with an additional backing plate located between the test specimen and the parallel rollers, see [Figure 16](#):

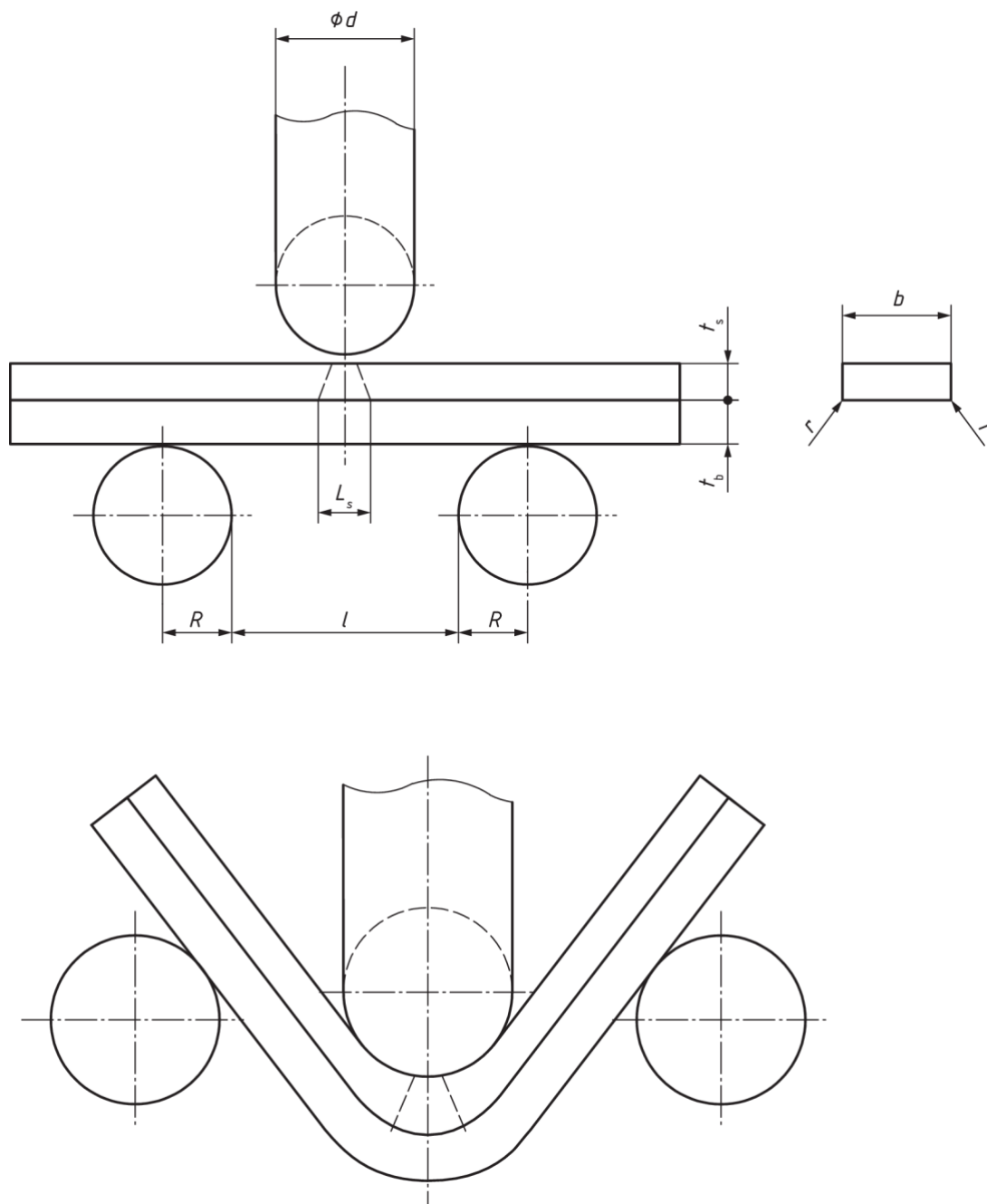

Figure 16 — Bending test with backing plate

Dimensions of additional backing plate should be comparable to that of the bend specimen, see [Figure 17](#). The length of the backing plate, L_b , should be $\geq L_t$.

Backing plates should have the same or comparable mechanical properties as the parent material.

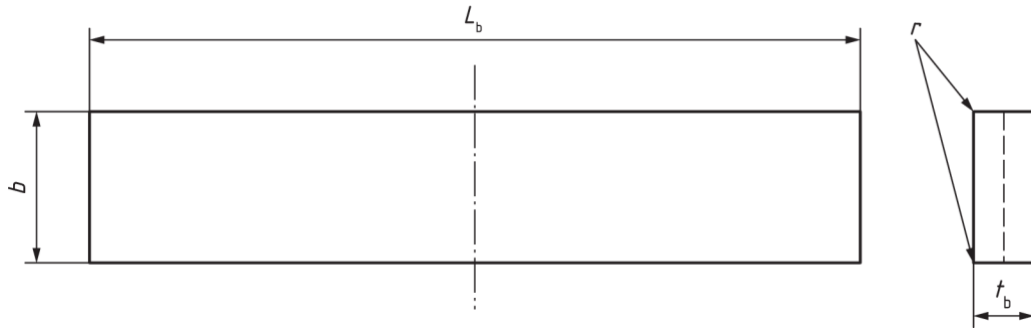

Figure 17 — Backing plate geometry

7.3 Diameter of former and roller

7.3.1 Steel, nickel and nickel alloys

The diameter of the former or the inner roller, d , shall be equal to $4 t_s$ for parent metal with minimum percentage elongation after fracture $A \geq 20$ %. For parent metal with elongation $A < 20$ %, [Formula \(4\)](#) shall be applied unless otherwise specified in the relevant application standard:

$$d = \frac{100 \times t_s}{A} - t_s \quad (4)$$

For combinations of different parent materials, the lowest value of A shall be used.

7.3.2 Aluminium and its alloys

For a parent metal with minimum percentage elongation after fracture $A > 5$ %, the diameter of the former or the inner roller shall be according to the value obtained with [Formula \(4\)](#) unless otherwise specified in the relevant application standard.

For minimum percentage elongation after fracture ≤ 5 %, annealing shall be carried out before testing to achieve the lowest-strength condition for the alloy. The former diameter shall be calculated with A given for the annealed condition.

For combinations of different parent materials, the lowest value of A shall be used.

7.4 Distance between and radius of parallel rollers

The distance between rollers, l , in [Figure 11](#), [Figure 12](#) and [Figure 13](#) shall be equal to the value obtained with [Formula \(5\)](#):

$$d + 2t_s + 1 \leq l \leq d + 3,5t_s \quad (5)$$

The distance between rollers, l , in [Figure 16](#) shall be equal to the value obtained with [Formula \(6\)](#):

$$d + 2(t_s + t_b) + 1 \leq l \leq d + 3,5(t_s + t_b) \quad (6)$$

The radius of rollers, R , in [Figures 11](#), [Figure 12](#), [Figure 13](#) and [Figure 16](#) shall be 20 mm or more.

7.5 Bending angle

The test is completed when the bending angle, α (other than 180°) reaches at least the value given in the relevant application standard. Otherwise, the following definitions may be applied:

- for Figure 11 to Figure 13 and Figure 16, the test is completed when the bending angle is approximately 180°, when the former axis has passed the axis of the rollers;
- for Figure 14, the test is completed when the bending angle is approximately 180° or a 3 mm wire cannot be inserted between the specimen and the lower fixture;
- for Figure 15, the test is completed when the outer roller has been moved 180° from the starting point.

The bending angle can be calculated from the measurement of the displacement of the former (see ISO 7438).

7.6 Bending elongation

When required for measuring elongation, the root or face bend test specimens shall have the following gauge lengths:

- for fusion welds, Formulae (7), (8) or (9):

$$L_o = L_s \quad (7)$$

$$L_o = 2L_s \quad (8)$$

$$L_o = L_s - t_s \quad (9)$$

- for pressure welds, electron beam welds and laser welds, Formula (10) or Formula (11):

$$L_o = t_s \quad (10)$$

$$L_o = 2t_s \quad (11)$$

The length L_o shall be equally distributed on both sides of the former axis.

L_o may be specified by the application standard or by agreement between the contracting parties.

8 Test results

After bending, both the external surface and the sides of the test specimen shall be examined.

The evaluation of the bend test specimen shall be made and reported in accordance with the relevant application standard.

9 Test report

The test report shall include at least the following information:

- a) reference to this document, i.e. ISO 5173:2023;

- b) identification of the test specimen (marking, type of parent material, heat treatment including thermal processing to eliminate hydrogen in the weld joints, etc.);
- c) shape and dimensions of the test specimen;
- d) type and abbreviation of bend test (root and face, transverse or longitudinal, side transverse bend test) see [Clause 3](#);
- e) conditions of testing (see [Clause 7](#)):
 - test methods (former or roller);
 - diameter of the former or inner roller;
 - distance between rollers;
 - radius of the rollers;
 - the use of U-type jig for bend test (if applicable).
- f) testing temperature;
- g) bending elongation and the original gauge length, if applicable
- h) type and dimensions of imperfections observed;
- i) bending angle;
- j) testing speed when known;
- k) application standard or application documents, when relevant
- l) any deviations from the procedure;
- m) any unusual features observed;
- n) the date of the test;
- o) test result.

An example of a typical test report is given in [Annex A](#).

Annex A
(informative)

Example of a test report

Number: _____

pWPS: _____

Test result “bend test” _____

Test result _____

Manufacturer: _____

Purpose of the examination: _____

Form of product: _____

Parent material: _____

Consumable: _____

Test temperature: _____

Any deviations from the procedure or any unusual features observed _____

Table A.1 —Bend test in accordance with ISO 5173:2023

Specimen N°/position	Type of test	Dimensions mm	Former diameter mm	Distance between rollers mm	Bend angle °	Original gauge length mm	Elongation %	Remark e.g. fracture appearance

Examiner or examining body: _____
(name, date and signature)

Approved by: _____
(name, date and signature)

Bibliography

- [1] ISO 7438, *Metallic materials — Bend test*