

**ISO 17640:2018 (E)**

**ISO 17640:2018(E)**

**ISO TC 44/SC 5/WG 2**

**Secretariat: AFNOR**

**Non-destructive testing of welds — Ultrasonic testing — Techniques, testing levels, and  
assessment**

© ISO 2018, Published in Switzerland

All rights reserved. Unless otherwise specified, no part of this publication may be reproduced or utilized otherwise in any form or by any means, electronic or mechanical, including photocopying, or posting on the internet or an intranet, without prior written permission. Permission can be requested from either ISO at the address below or ISO's member body in the country of the requester.

ISO copyright office

Ch. de Blandonnet 8 • CP 401

CH-1214 Vernier, Geneva, Switzerland

Tel. + 41 22 749 01 11

Fax + 41 22 749 09 47

[copyright@iso.org](mailto:copyright@iso.org)

[www.iso.org](http://www.iso.org)

## Contents

Foreword.....	iv
<b>1</b> Scope.....	<b>5</b>
<b>2</b> Normative references.....	<b>5</b>
<b>3</b> Terms and definitions.....	<b>6</b>
<b>4</b> Symbols.....	<b>6</b>
<b>5</b> General.....	<b>7</b>
<b>6</b> Information required prior to testing.....	<b>7</b>
6.1 Items to be specified.....	7
6.2 Specific information required before testing.....	8
6.3 Written test procedure.....	8
<b>7</b> Requirements for personnel and equipment.....	<b>8</b>
7.1 Personnel qualifications.....	8
7.2 Test equipment.....	9
7.3 Probe parameters.....	9
7.3.1 Test frequency.....	9
7.3.2 Angles of incidence.....	9
7.3.3 Transducer size.....	9
7.3.4 Adaptation of probes to curved scanning surfaces.....	9
7.3.5 Coupling media.....	10
<b>8</b> Testing volume.....	<b>10</b>
<b>9</b> Preparation of scanning surfaces.....	<b>10</b>
<b>10</b> Parent metal testing.....	<b>10</b>
<b>11</b> Range and sensitivity setting.....	<b>11</b>
11.1 General.....	11
11.2 Reference for sensitivity setting.....	12
11.3 Evaluation levels.....	13
11.4 Transfer correction.....	13
11.5 Signal-to-noise ratio.....	13
<b>12</b> Testing levels.....	<b>13</b>
<b>13</b> Testing techniques.....	<b>14</b>
13.1 General.....	14
13.2 Manual scan path.....	14
13.3 Testing for imperfections perpendicular to the testing surface.....	14
13.4 Location of discontinuities.....	14
13.5 Evaluation of indications.....	14
13.5.1 General.....	14
13.5.2 Maximum echo amplitude.....	14
13.5.3 Discontinuity length.....	14
13.5.4 Discontinuity height.....	14
13.5.5 Characterization of discontinuities.....	14
<b>14</b> Test report.....	<b>14</b>
<b>Annex A (normative) Testing levels for various types of welded joints.....</b>	<b>17</b>
<b>Bibliography.....</b>	<b>45</b>

## Foreword

ISO (the International Organization for Standardization) is a worldwide federation of national standards bodies (ISO member bodies). The work of preparing International Standards is normally carried out through ISO technical committees. Each member body interested in a subject for which a technical committee has been established has the right to be represented on that committee. International organizations, governmental and non-governmental, in liaison with ISO, also take part in the work. ISO collaborates closely with the International Electrotechnical Commission (IEC) on all matters of electrotechnical standardization.

The procedures used to develop this document and those intended for its further maintenance are described in the ISO/IEC Directives, Part 1. In particular, the different approval criteria needed for the different types of ISO documents should be noted. This document was drafted in accordance with the editorial rules of the ISO/IEC Directives, Part 2 (see [www.iso.org/directives](http://www.iso.org/directives)).

Attention is drawn to the possibility that some of the elements of this document may be the subject of patent rights. ISO shall not be held responsible for identifying any or all such patent rights. Details of any patent rights identified during the development of the document will be in the Introduction and/or on the ISO list of patent declarations received (see [www.iso.org/patents](http://www.iso.org/patents)).

Any trade name used in this document is information given for the convenience of users and does not constitute an endorsement.

For an explanation of the voluntary nature of standards, the meaning of ISO specific terms and expressions related to conformity assessment, as well as information about ISO's adherence to the World Trade Organization (WTO) principles in the Technical Barriers to Trade (TBT) see [www.iso.org/iso/foreword.html](http://www.iso.org/iso/foreword.html).

This document was prepared by Technical Committee ISO/TC 44, *Welding and allied processes*, Subcommittee SC 5, *Testing and inspection of welds*.

Any feedback, question or request for official interpretation related to any aspect of this document should be directed to the Secretariat of ISO/TC 44/SC 5 via your national standards body. A complete listing of these bodies can be found at [www.iso.org/members.html](http://www.iso.org/members.html). Official interpretations, where they exist, are available from this page: <https://committee.iso.org/sites/tc44/home/interpretation.html>.

This fourth edition cancels and replaces the third edition (ISO 17640:2017), which has been technically revised. The main change compared to the previous edition is that Figure A.4 a) and b) has been corrected.

# Non-destructive testing of welds — Ultrasonic testing — Techniques, testing levels, and assessment

## 1 Scope

This document specifies techniques for the manual ultrasonic testing of fusion-welded joints in metallic materials of thickness  $\geq 8$  mm which exhibit low ultrasonic attenuation (especially that due to scatter) at object temperatures from 0 °C to 60 °C. It is primarily intended for use on full penetration welded joints where both the welded and parent material are ferritic.

Where material-dependent ultrasonic values are specified in this document, they are based on steels having an ultrasonic sound velocity of  $(5\,920 \pm 50)$  m/s for longitudinal waves and  $(3\,255 \pm 30)$  m/s for transverse waves.

This document specifies four testing levels, each corresponding to a different probability of detection of imperfections. Guidance on the selection of testing levels A, B, and C is given in Annex A.

This document specifies that the requirements of testing level D, which is intended for special applications, be in accordance with general requirements. Testing level D can only be used when defined by specification. This includes tests of metals other than ferritic steel, tests on partial penetration welds, tests with automated equipment, and tests at object temperatures outside the range 0 °C to 60 °C.

This document can be used for the assessment of discontinuities, for acceptance purposes, by either of the following techniques:

- a) evaluation based primarily on length and echo amplitude of the discontinuity;
- b) evaluation based on characterization and sizing of the discontinuity by probe movement techniques.

## 2 Normative references

The following documents are referred to in the text in such a way that some or all of their content constitutes requirements of this document. For dated references, only the edition cited applies. For undated references, the latest edition of the referenced document (including any amendments) applies.

ISO 5577, *Non-destructive testing — Ultrasonic testing — Vocabulary*

ISO 9712, *Non-destructive testing — Qualification and certification of NDT personnel*

ISO 11666, *Non-destructive testing of welds — Ultrasonic testing — Acceptance levels*

ISO 16810, *Non-destructive testing — Ultrasonic testing — General principles*

ISO 16811, *Non-destructive testing — Ultrasonic testing — Sensitivity and range setting*

ISO 16826, *Non-destructive testing — Ultrasonic testing — Examination for discontinuities perpendicular to the surface*

ISO 17635, *Non-destructive testing of welds — General rules for metallic materials*

ISO 23279, *Non-destructive testing of welds — Ultrasonic testing — Characterization of discontinuities in welds*

EN 12668 (all parts), *Non-destructive testing — Characterization and verification of ultrasonic examination equipment*

### 3 Terms and definitions

For the purposes of this document, the terms and definitions given in ISO 5577 and ISO 17635 apply.

ISO and IEC maintain terminological databases for use in standardization at the following addresses:

- ISO Online browsing platform: available at <https://www.iso.org/obp>
- IEC Electropedia: available at <http://www.electropedia.org/>

### 4 Symbols

The symbols in Table 1 apply.

**Table 1 — Symbols**

Symbol	Definition	Unit
AL	acceptance level	—
$D_{\text{DSR}}$	diameter of the disk-shaped reflector (flat-bottomed hole)	mm
$h$	extension of the discontinuity in depth direction	mm
$l$	length of the discontinuity	mm
$l_x$	projected length of the discontinuity in the $x$ -direction	mm
$l_y$	projected length of the discontinuity in the $y$ -direction	mm
$p$	full skip distance	mm
$t$	thickness of parent material <sup>a</sup>	mm
$x$	position of the discontinuity in the longitudinal direction	mm
$y$	position of the discontinuity in the transverse direction	mm
$z$	position of the discontinuity in the depth direction	mm

<sup>a</sup> If the joined parts are not of equal thickness,  $t$  represents the smallest thickness.

Indications shall be considered to be originating from either longitudinal or transverse discontinuities, depending on the direction of their major dimension with respect to the weld axis,  $x$ , in accordance with Figure 1.

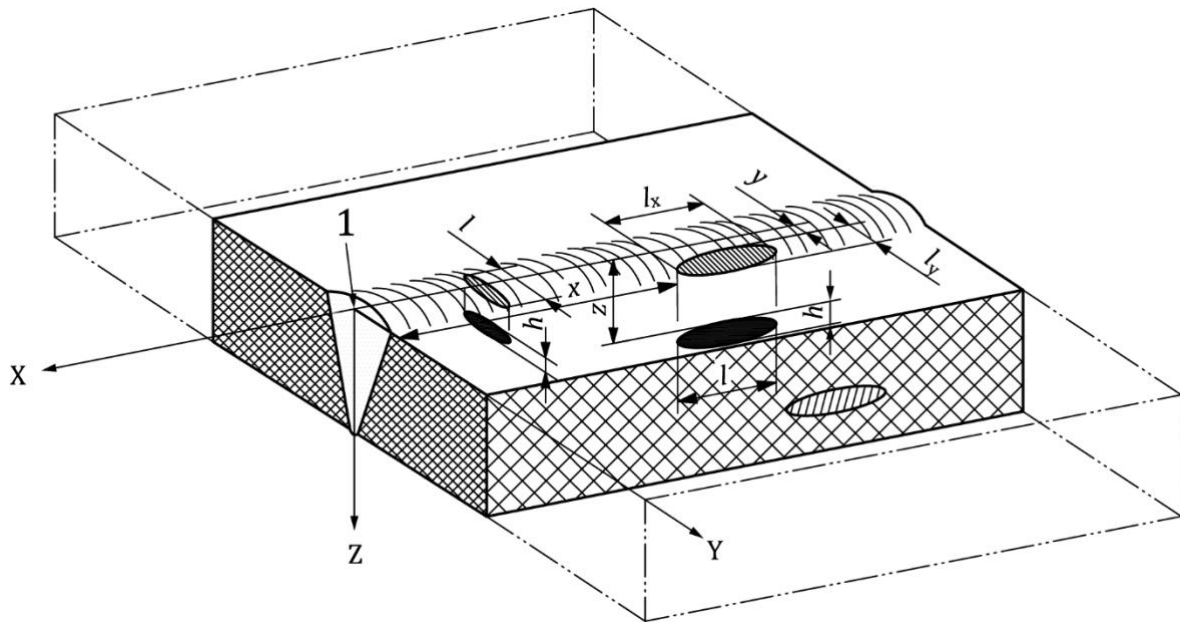
**Key**

1 origin

**Figure 1 — Coordinate system for defining the location of discontinuities**

## 5 General

The purpose of this document is to describe general techniques of ultrasonic weld testing, using standard criteria, for the most commonly used welded joints at object temperatures in the range 0 °C to 60 °C. The specific requirements of this document cover the test equipment, preparation, performance of testing, and reporting. The parameters specified, in particular those for the probes, are compatible with the requirements of ISO 11666 and ISO 23279.

If the joined parts are not of equal thickness, the smallest thickness shall be considered.

The techniques used shall be specified.

## 6 Information required prior to testing

### 6.1 Items to be specified

These include:

- a) method for setting the reference level;
- b) method to be used for the evaluation of discontinuities;
- c) acceptance levels;
- d) testing level;
- e) manufacturing and operation stage(s) at which the testing is to be carried out;
- f) qualification of personnel;

- g) extent of the testing for transverse discontinuities;
- h) requirements for additional tandem testing (according to ISO 16826);
- i) parent metal testing prior to and/or after welding;
- j) whether or not a written test procedure is required;
- k) requirements for written test procedures.

## 6.2 Specific information required before testing

Before any testing of a welded joint can begin, the operator shall have access to the following essential information:

- a) written test procedure, if required (see 6.3);
- b) type(s) of parent material and product form (i.e. cast, forged, rolled);
- c) manufacturing or operation stage at which testing is to be made, including heat treatment, if any;
- d) time and extent of any post-weld heat treatment;
- e) joint preparation and dimensions;
- f) requirements for surface conditions;
- g) welding procedure or relevant information on the welding process;
- h) reporting requirements;
- i) acceptance levels;
- j) extent of testing, including requirements for transverse discontinuities, if relevant;
- k) testing level;
- l) personnel qualification level;
- m) procedures for corrective actions when unacceptable discontinuities are revealed.

## 6.3 Written test procedure

The definitions and requirements in this document normally satisfy the need for a written test procedure.

Where this is not the case, or where the techniques described in this document are not applicable to the welded joint to be tested, additional written test procedures shall be used, if required by specification.

## 7 Requirements for personnel and equipment

### 7.1 Personnel qualifications

Personnel performing testing in accordance with this document shall be qualified to an appropriate level in ultrasonic testing in accordance with ISO 9712 or equivalent in the relevant industrial sector.



In addition to a general knowledge of ultrasonic weld testing, personnel shall also be familiar with testing problems specifically associated with the type of welded joints to be tested.

## 7.2 Test equipment

Any equipment used for testing in conjunction with this document shall comply with the requirements of EN 12668 (all parts).

## 7.3 Probe parameters

### 7.3.1 Test frequency

The frequency shall be within the range 2 MHz to 5 MHz and shall be selected to consider the properties of the test object and to comply with the specified acceptance levels, e.g. those of ISO 11666.

Higher frequencies may be used to improve range resolution if this is necessary when using standards for acceptance levels based on characterization of discontinuities, e.g. ISO 23279.

Lower frequencies may be used for testing at long sound paths and/or when the material shows high attenuation.

### 7.3.2 Angles of incidence

When testing is carried out with transverse waves and techniques that require the ultrasonic beam to be reflected from an opposite surface, care shall be taken to ensure that the angle between the beam and the normal to the opposite reflecting surface is between 35° and 70°. Where more than one beam angle is used, at least one of the angle-beam probes used shall conform to this requirement. One of the beam angles used shall ensure that the weld fusion faces are tested at, or as near as possible to, normal incidence. When the use of two or more beam angles is specified, the difference between the nominal beam angles shall be 10° or greater.

Angles of incidence at the probe and opposite reflecting surface, when curved, may be determined by drawing a sectional view of the weld or in accordance with the techniques given in ISO 16811. Where angles of incidence cannot be determined as specified by this document, the test report shall contain a comprehensive description of the scans used and the extent of any incomplete coverage caused, together with an explanation of the difficulties encountered.

### 7.3.3 Transducer size

The transducer size shall be chosen according to the ultrasonic path to be used and the frequency.

The smaller the transducer, the smaller the length and width of the near field, and the larger the beam spread in the far field at a given frequency.

Small probes having 6 mm to 12 mm diameter transducers (or rectangular transducers of equivalent area) are therefore most useful when working at short sound paths. For longer sound paths, i.e. greater than 100 mm for single-transducer and greater than 200 mm for angle-beam probes, a transducer size of 12 mm to 24 mm is more suitable.

### 7.3.4 Adaptation of probes to curved scanning surfaces

The gap,  $g$ , between test surface and bottom of the probe shall not be greater than 0,5 mm.

For flat probes on cylindrical or spherical surfaces, this requirement can be checked with Formula (1):

$$g = a^2 / 4D \quad (1)$$

where

$a$  is the dimension of the probe in the direction of curvature, in mm;

$D$  is the diameter of the test object, in mm.

If a value for  $g$  larger than 0,5 mm results from Formula (1), the probe shall be adapted to the surface and the sensitivity and range shall be set accordingly.

For spherical or complex shaped surfaces, Formula (1) shall be applied in both length and width direction of the probe (possible differences in curvature and/or probe dimensions).

### 7.3.5 Coupling media

The coupling media shall be in accordance with ISO 16810. The coupling medium used for range and sensitivity setting and for the test shall be the same.

## 8 Testing volume

The testing volume (see Figure 2) is defined as the zone which includes weld and parent material and the width of the heat-affected zone on each side of the weld or at least 10 mm if the width of the heat-affected zone is not known.

In all cases, scanning shall cover the whole testing volume. If individual sections of this volume cannot be covered in at least one scanning direction, or if the angles of incidence with the opposite surface do not meet the requirements of 7.3.2, alternative or supplementary ultrasonic techniques or other non-destructive techniques shall be agreed upon. This may, in some cases, require removal of the weld reinforcement.

Supplementary techniques can require testing using dual-transducer angle-beam probes, creeping wave probes, further ultrasonic techniques or any other suitable method, e.g. liquid penetrant, magnetic particle, radiographic testing. In selecting alternative or supplementary techniques, due consideration should be given to the type of weld and probable orientation of any imperfections to be detected.

## 9 Preparation of scanning surfaces

Scanning surfaces shall be wide enough to permit the testing volume (see Figure 2) to be fully covered. Alternatively, the width of the scanning surfaces may be smaller if equivalent coverage of the testing volume can be achieved by scanning from both the upper and the lower surface of the joint.

Scanning surfaces shall be even and free from foreign matter likely to interfere with probe coupling (e.g. rust, loose scale, weld spatter, notches, grooves). Waviness of the test surface shall not result in a gap between the probe and test surfaces greater than 0,5 mm. These requirements shall be ensured by dressing, if necessary. Local variations in surface contour, e.g. along the edge of the weld, which result in a gap beneath the probe of up to 1 mm, can only be permitted if at least one additional beam angle is employed from the affected side at the weld. This additional scanning is necessary to compensate for the reduced weld coverage that will occur with a gap of this dimension.

Scanning surfaces and surfaces from which the sound beam is reflected shall allow undisturbed coupling and reflection.

## 10 Parent metal testing

The parent metal, in the scanning zone area (see Figure 2), shall be tested with straight-beam probes prior to or after welding, unless it can be demonstrated (e.g. by previous testing during the fabrication process) that the angle-beam testing of the weld is not influenced by the presence of the imperfections or high attenuation.

Where imperfections are found, their influence on the proposed angle-beam testing shall be assessed and, if necessary, the techniques adjusted correspondingly. When satisfactory coverage by ultrasonic testing is seriously affected, other test techniques (e.g. radiographic testing) shall be considered.

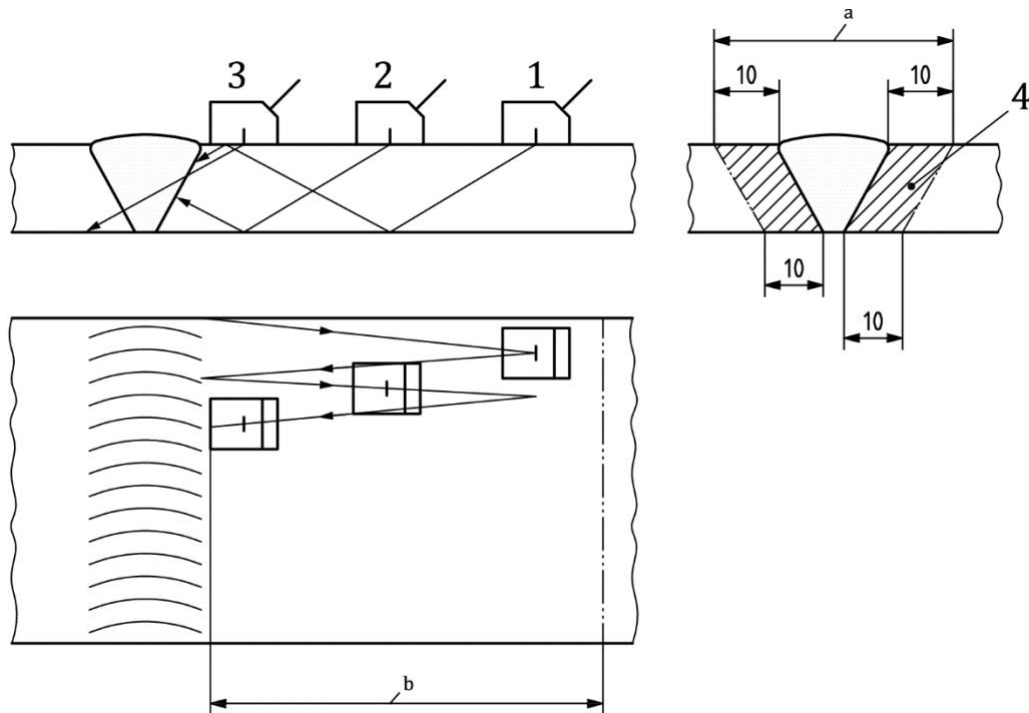
**Key**

- 1 position 1, taking into account the width of the heat-affected zone
- 2 position 2
- 3 position 3
- 4 heat-affected zone
- a Width of testing volume.
- b Scanning zone width, not including the width of the weld because of the presence of the weld reinforcement.

**Figure 2 — Example of testing volume to be covered when scanning for longitudinal discontinuities**

## 11 Range and sensitivity setting

### 11.1 General

Setting of range and sensitivity shall be carried out prior to each testing in accordance with this document and ISO 16811, taking the influence of temperature into account. The temperature difference during range and sensitivity setting and during the test shall be within  $\pm 15$  °C.

Checks to confirm these settings shall be performed at least every 4 h and upon completion of the testing. Checks shall also be carried out whenever a system parameter is changed or changes in the equivalent settings are suspected.

If deviations greater than 2 dB, or 1 % of range, are found during these checks, the corrections given in Table 2 shall be carried out.

**Table 2 — Sensitivity and range corrections**

Sensitivity		
1	Deviations $\leq 2$ dB	No action required.
2	$2 \text{ dB} < \text{deviation} \leq 4 \text{ dB}$	Setting shall be corrected before the testing is continued.

3	Reduction of the sensitivity > 4 dB	Setting shall be corrected and all testing carried out with the equipment over the previous period shall be repeated.
4	Increase in sensitivity > 4 dB	Setting shall be corrected and all recorded indications shall be re-examined.
<b>Range</b>		
1	Deviations < 1 % of the range	No action required.
2	1 % of the range < deviation ≤ 2 % of the range	Setting shall be corrected before testing is continued.
3	Deviations > 2 % of the range	Setting shall be corrected and testing carried out with the equipment over the previous period shall be repeated.

**11.2 Reference for sensitivity setting**

One of the following techniques for setting the reference shall be used.

The use of these techniques may not result in equal test results.

Different testing results can occur by usage of different techniques for sensitivity setting.

- Technique 1: the reference is a distance-amplitude curve (DAC) for side-drilled holes of diameter 3 mm.
- Technique 2: the references for transverse and longitudinal waves using the distance-gain-size (DGS) system based on the diameter of the disk-shaped reflectors ( $D_{DSR}$ ) are given in Tables 3 and 4, respectively.
- Technique 3: the reference notch shall be rectangular, 1 mm wide with a depth of 1 mm. This technique applies only for the thickness range  $8 \text{ mm} \leq t < 15 \text{ mm}$  and only for beam angles  $\geq 70^\circ$ .
- Technique 4: for the tandem technique, the reference is a disk-shaped reflector (flat-bottomed hole) of 6 mm diameter (for all thicknesses), perpendicular to the scanning surface. This technique is applicable only for beam angle  $45^\circ$  and thickness  $t \geq 40 \text{ mm}$ .

The length of the side-drilled holes and notches shall be greater than the width of the sound beam at -20 dB amplitude.

**Table 3 — Reference levels for acceptance levels 2 and 3 for technique 2 using angle-beam scanning with transverse waves**

Nominal probe frequency MHz	Thickness of parent material, $t$					
	$8 \text{ mm} \leq t < 15 \text{ mm}$		$15 \text{ mm} \leq t < 40 \text{ mm}$		$40 \text{ mm} \leq t < 100 \text{ mm}$	
	AL 2	AL 3	AL 2	AL 3	AL 2	AL 3
2,0 to 2,5	—	—	$D_{DSR} = 2,5 \text{ mm}$	$D_{DSR} = 2,5 \text{ mm}$	$D_{DSR} = 3,0 \text{ mm}$	$D_{DSR} = 3,0 \text{ mm}$
3,0 to 5,0	$D_{DSR} = 1,5 \text{ mm}$	$D_{DSR} = 1,5 \text{ mm}$	$D_{DSR} = 2,0 \text{ mm}$	$D_{DSR} = 2,0 \text{ mm}$	$D_{DSR} = 3,0 \text{ mm}$	$D_{DSR} = 3,0 \text{ mm}$

**Table 4 — Reference levels for acceptance levels 2 and 3 for technique 2 using straight-beam scanning with longitudinal waves**

Nominal probe frequency MHz	Thickness of parent material, $t$					
	$8 \text{ mm} \leq t < 15 \text{ mm}$		$15 \text{ mm} \leq t < 40 \text{ mm}$		$40 \text{ mm} \leq t < 100 \text{ mm}$	
	AL 2	AL 3	AL 2	AL 3	AL 2	AL 3

2,0 to 2,5	—	—	$D_{DSR} = 2,5$ mm	$D_{DSR} = 2,5$ mm	$D_{DSR} = 3,0$ mm	$D_{DSR} = 3,0$ mm
3,0 to 5,0	$D_{DSR} = 2,0$ mm	$D_{DSR} = 2,0$ mm	$D_{DSR} = 2,0$ mm	$D_{DSR} = 2,0$ mm	$D_{DSR} = 3,0$ mm	$D_{DSR} = 3,0$ mm

### 11.3 Evaluation levels

All indications equal to or exceeding the following levels shall be evaluated.

The evaluation levels for techniques 1 to 4 are given in ISO 11666:2018, Table A.1.

### 11.4 Transfer correction

When separate blocks are used for establishing reference levels, a measurement shall be made of the transfer differences, between test object and reference block, at a representative number of locations. Suitable techniques are described in ISO 16811.

If the differences are less than or equal to 2 dB, correction is not required.

If the differences are greater than 2 dB but smaller than or equal to 12 dB, they shall be compensated for.

If transfer losses exceed 12 dB, the reason shall be considered and further preparation of the scanning surfaces shall be carried out, if applicable.

When there are no apparent reasons for high correction values, the attenuation, at various locations on the test object, shall be measured and, where it is found to vary significantly, corrective actions shall be considered.

### 11.5 Signal-to-noise ratio

During testing of the weld, the noise level, excluding spurious surface indications, shall remain at least 12 dB below the evaluation level. This requirement may be relaxed subject to specification.

## 12 Testing levels

Quality requirements for welded joints are mainly associated with the material, welding process and service conditions. To accommodate all of these requirements, this document specifies four testing levels (A, B, C, and D).

From testing level A to testing level C, an increasing probability of detection is achieved by an increasing testing coverage, e.g. number of scans, surface dressing. Testing level D may be agreed for special application using a written procedure which shall take into account the general requirements of this document.

In general, the testing levels are related to quality levels (e.g. ISO 5817). The appropriate testing level may be specified by standards for testing of welds (e.g. ISO 17635), product standards or other documents.

When ISO 17635 is specified, the recommended testing levels are as given in Table 5.

**Table 5 — Recommended testing levels**

Testing level	Quality level in ISO 5817
A	C, D
B	B
C	By agreement
D	Special application

Specific requirements for testing levels A to C are given for various types of joints in Annex A. The joint types shown are ideal examples only; where actual weld conditions or accessibility do not conform exactly to those shown, the testing technique shall be modified to satisfy the general requirements of this document and the specific testing level required. For these cases, a written test procedure shall be prepared.

## 13 Testing techniques

### 13.1 General

Ultrasonic testing shall be performed in accordance with ISO 16810 with the addition of the specifications in 13.2 to 13.5.

### 13.2 Manual scan path

During angle-beam scanning (as illustrated in Figure 2), a slight swivelling movement up to an angle of approximately 10° on either side of the nominal beam direction shall be applied to the probe.

### 13.3 Testing for imperfections perpendicular to the testing surface

Subsurface planar imperfections perpendicular to the testing surface are difficult to detect with single single-transducer angle-beam techniques. For such imperfections, specific testing techniques should be considered, particularly for welds in thicker materials. Use of these testing techniques shall be defined by specification.

### 13.4 Location of discontinuities

The location of discontinuities shall be defined by reference to a coordinate system, e.g. as shown in Figure 1. A point on the testing surface shall be selected as the origin for these measurements.

Where testing is carried out from more than one surface, reference points shall be established on each surface. In this case, care shall be taken to establish a positional relationship between all reference points used, so that the absolute location of all discontinuities can be established from any nominated reference point.

In the case of circumferential welds, this can require the establishment of the inner and outer reference points prior to assembly for welding.

### 13.5 Evaluation of indications

#### 13.5.1 General

All relevant indications above the evaluation level shall be assessed in accordance with 13.5.2 to 13.5.4.

#### 13.5.2 Maximum echo amplitude

The echo amplitude shall be maximized by probe movement and recorded in relation to the reference level.

#### 13.5.3 Discontinuity length

The length of a discontinuity, in either the longitudinal or transverse direction ( $l_x$ ,  $l_y$ ), shall, where possible, be determined using the technique specified in the acceptance levels standard, unless otherwise agreed.

#### 13.5.4 Discontinuity height

The height of a discontinuity shall only be determined if required by specification.

#### 13.5.5 Characterization of discontinuities

If specified, discontinuities shall be characterized in accordance with ISO 23279.

## 14 Test report

The test report shall include at least the following information:

- a) an identification of the object under test:

- 1) the material and product form;
  - 2) the dimensions;
  - 3) the location of tested weld/welded joint, sketch showing geometrical configuration (if necessary);
  - 4) a reference to the welding procedure, specification and heat treatment;
  - 5) the state of manufacture;
  - 6) the surface conditions;
  - 7) the temperature of the test object;
- b) the contract requirements, e.g. specifications, guidelines, special agreements;
  - c) the place and date of testing;
  - d) an identification of test organizations and identification and certification of operator;
  - e) the maker and type of the ultrasonic instrument with identification number, if required;
  - f) the maker, type, nominal frequency, size of transducer and actual angle of incidence of probes used with identification number, if required;
  - g) an identification of reference blocks used with a sketch, if necessary;
  - h) the coupling medium;
  - i) the testing level(s) and reference to written procedure when used;
  - j) the extent of testing;
  - k) the location of the scanning areas;
  - l) the reference points and details of the coordinate system used as specified in 13.4;
  - m) an identification of probe positions, as specified in Annex A or by use of a sketch;
  - n) the range setting;
  - o) the method and values used for sensitivity setting (gain setting for reference levels and values used for transfer corrections);
  - p) the reference levels;
  - q) the result of the parent material test;
  - r) the standards for acceptance levels;
  - s) the deviations from this document or contract requirements;
  - t) the coordinates of the discontinuities, as specified in 13.4, with details of associated probes and corresponding probe positions;

- u) the maximum echo amplitudes as specified in 13.5.2 and information, if required, on the type and size of discontinuities;
- v) the lengths of discontinuities as specified in 13.5.3;
- w) the results of evaluation according to specified acceptance levels;
- x) a reference to this document, i.e. ISO 17640.



## Annex A (normative)

### Testing levels for various types of welded joints

See Figures A.1 to A.7 and Tables A.1 to A.7.

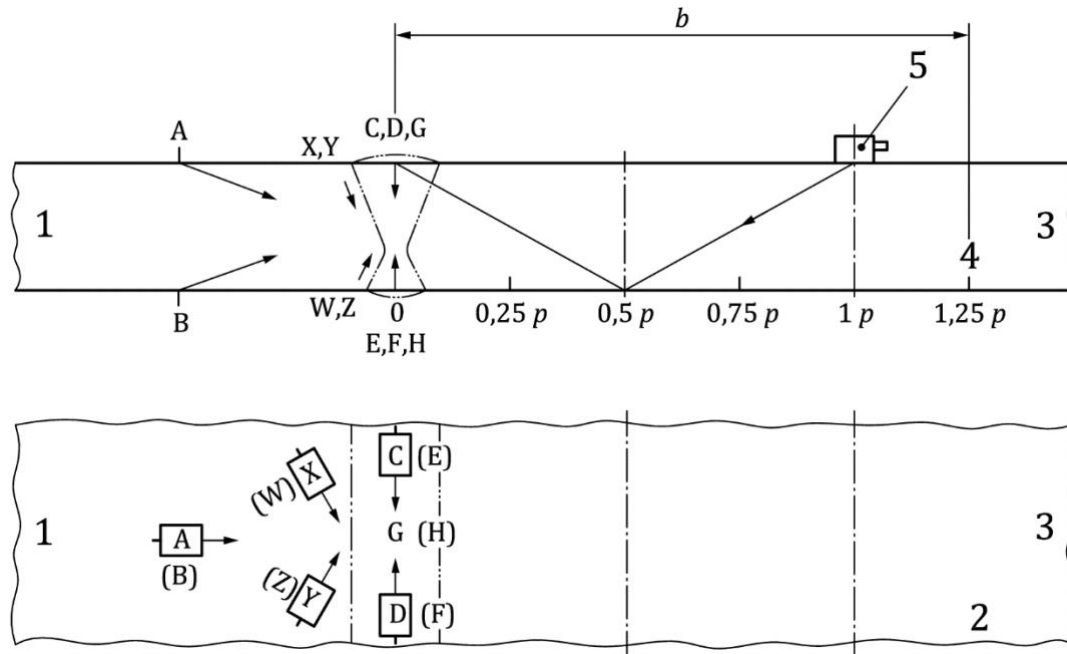

#### Key

1	side 1
2	top view
3	side 2
4	side view
5	angle-beam probe
A, B, C, D, E, F, G, H, W, X, Y, Z	probe positions (shown on one side only, but can be mirrored about the weld centre line)
$b$	scanning zone width (SZW) related to skip distance, $p$ , to cover the testing volume (see Clause 8)
$p$	full-skip distance

**Figure A.1 — Examples of probe positions for a butt joint**

Table A.1 — Butt joints in plates and pipes

Testing level	Thickness of the parent material mm	Longitudinal discontinuities						Transverse discontinuities			
		Beam angles	Probe positions	Scanning zone width	Probe positions	Total number scans	Notes	Required number of		Total number scans	Notes
								L-scans	N-scans		
A	$8 \leq t < 15$	1	A or B	$1,25 p$	—	2	a	1	(X and Y) or (W and Z)	4	c
	$15 \leq t < 40$	1	A or B	$1,25 p$	—	2	a	1	(X and Y) or (W and Z)	4	c
B	$8 \leq t < 15$	1	A or B	$1,25 p$	—	2	e	1	(X and Y) or (W and Z)	4	c
	$15 \leq t < 40$	2 <sup>f</sup>	A or B	$1,25 p$	—	4	b,e	1	(X and Y) or (W and Z)	4	c
	$40 \leq t < 60$	2	A or B	$1,25 p$	—	4	b	2	(X and Y) or (W and Z)	8	c
	$60 \leq t \leq 100$	2	A or B	$1,25 p$	—	4	b	2	(C and D) or (E and F)	4	c,d
C	$8 \leq t < 15$	1	A or B	$1,25 p$	G or H	3	d	1	(C and D) or (E and F)	2	d
	$15 \leq t \leq 40$	2	A or B	$1,25 p$	G or H	5	b,d	2	(C and D) or (E and F)	4	d
	>40	2	A or B	$1,25 p$	G or H	5	b,d	2	(C and D) or (E and F)	4	d

a May be limited by agreement to one scan from one side.  
 b Additional testing by tandem technique by special agreement.  
 c Required only by special agreement.  
 d The surface of the weld cap shall comply with the requirement in Clause 9. This can require dressing of the weld cap. However, for single-sided circumferential pipe welds, the outside cap only is to be dressed.  
 e If only accessible from one side, two angles shall be used.

<sup>f</sup> In the range  $15 \text{ mm} \leq t \leq 25 \text{ mm}$ , one angle is sufficient provided the frequency is below 3 MHz.

NOTE 1 For symbols, see Figure A.1.

NOTE 2 L-scan: scan for longitudinal discontinuities using angle-beam probes; N-scan: scan using straight-beam probes; T-scan: scan for transverse discontinuities using angle-beam probes;  $p$  is the full skip distance.



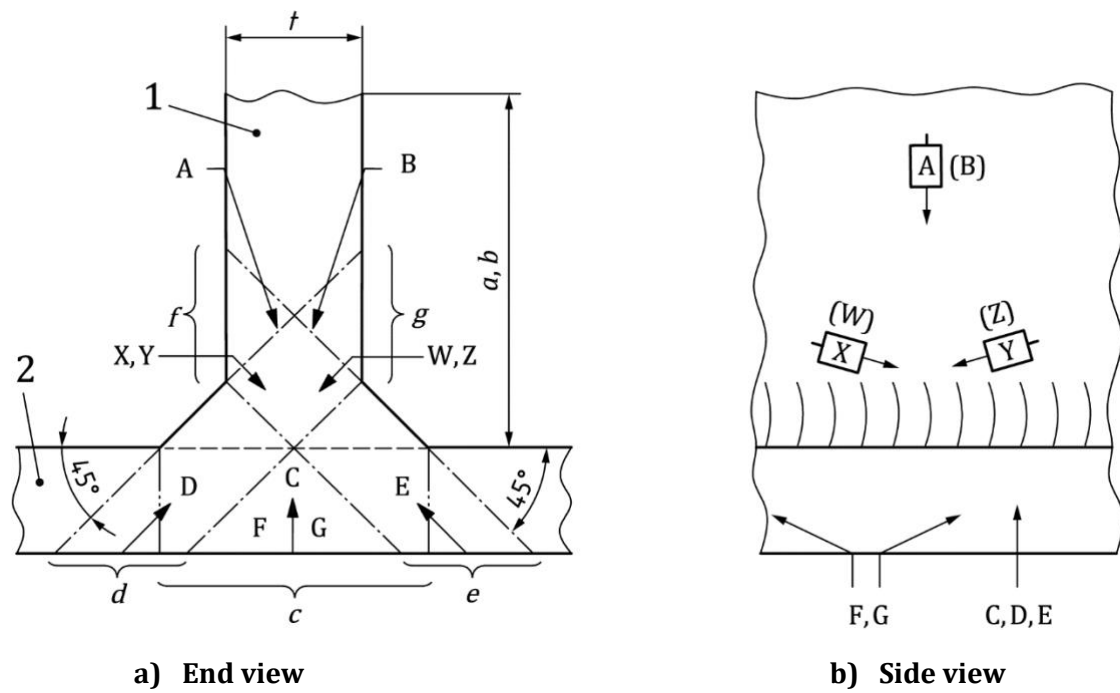

**Key**

1	component 1
2	component 2
A, B, C, D, E, F, G, W, X, Y, Z	probe positions
<i>a, b, c, d, e, f, g</i>	scanning zone width indicators
<i>t</i>	thickness

**Figure A.2 — Examples of probe positions for a structural T-joint**



Table A.2 — Structural T-joints

Testing level	Thickness of the parent material mm	Longitudinal discontinuities						Transverse discontinuities				
		Required number of					Total number of scans	Required number of			Total number of scans	Notes
		Beam angles	Probe positions	Scanning zone width	Probe positions	Scanning zone width		Beam angles	Probe positions	Scanning zone width		
		L-scans			N-scans			T-scans				
A	$8 \leq t < 15$	1	A or B	$1,25 p$	$C^c$	—	1	—	—	—	—	a
	$15 \leq t < 40$	1	A or B	$1,25 p$	$C^c$	$c$	2	—	—	—	—	a
B	$8 \leq t < 15$	1	A or B	$1,25 p$	$C^c$	—	2	1	F and G	$c$	2	b
	$15 \leq t < 40$	1	A and B	$1,25 p$	$C^c$	$c$	3	1	(F and G) or (X and Y) or (W and Z)	$c$ $f+g$	2	b
	$40 \leq t \leq 100$	2	A and B	$0,75 p$	$C^c$	$c$	5	1	(F and G) or (X and Y) or (W and Z)	$c$ $f+g$	2	b
C	$8 \leq t < 15$	1	A and B	$1,25 p$	$C^c$	$c$	3	2	F and G	$c$ $f+g$	4	b
	$15 \leq t < 40$	2 1	(A and B) and (D and E)	$1,25 p$ $d+e$	$C^c$	$c$	7	1	(F and G) and (X and Y) or (W and Z)	$c$ $f+g$	4	b

	$40 \leq t \leq 100$	2 1	(A and B) and (D and E)	$0,75 p$ $d + e$	C <sup>c</sup>	<i>c</i>	7	2	(F and G) and (X and Y) or (W and Z)	<i>c</i> $f + g$	8	b
	>100	3 1	(A and B) and (D and E)	$0,75 p$ $d + e$	C <sup>c</sup>	<i>c</i>	9	2	(F and G) and (X and Y) or (W and Z)	<i>c</i> $f + g$	8	b

- <sup>a</sup> Not applicable.
- <sup>b</sup> Shall be carried out by special agreement only.
- <sup>c</sup> To be substituted by tandem technique from A or B if C is not possible.

NOTE 1 For symbols, see Figure A.2.

NOTE 2 L-scan: scan for longitudinal discontinuities using angle-beam probes; N-scan: scan using straight-beam probes; T-scan: scan for transverse discontinuities using angle-beam probes; *p* is the full skip distance.



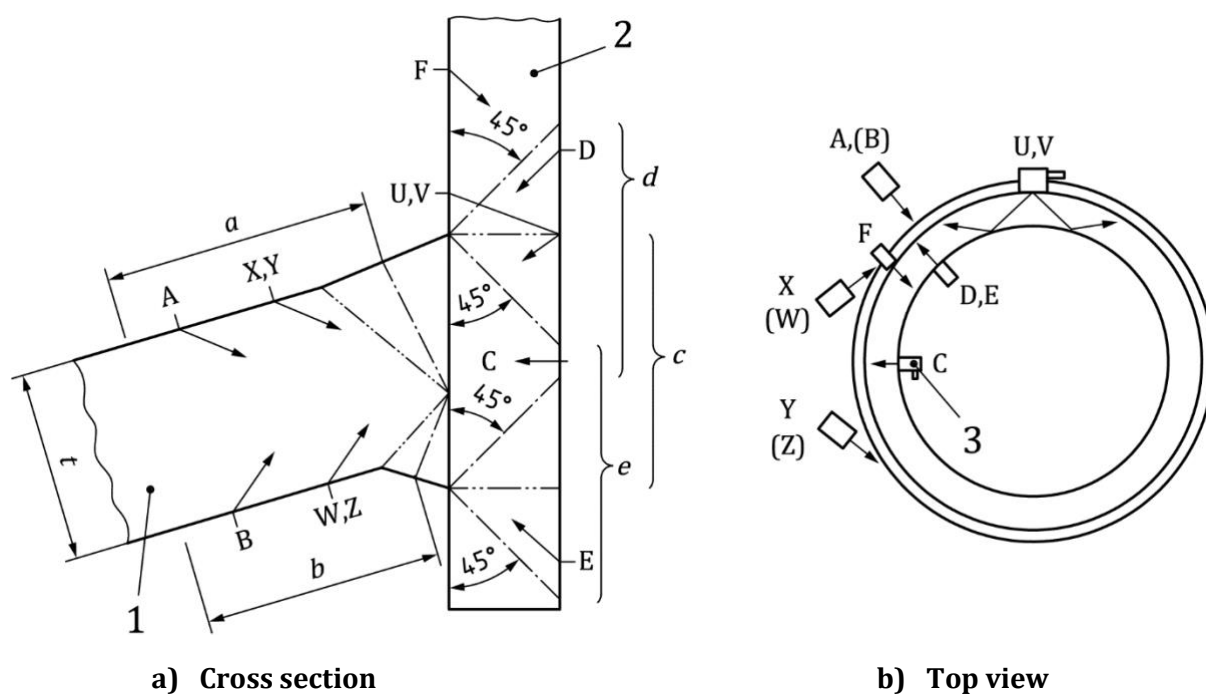

**Key**

1	component 1, cylindrical shell/flat plate
2	component 2, nozzle
3	straight-beam probe
A, B, C, D, E, F, U, V, W, X, Y, Z	probe positions
a, b, c, d, e	scanning zone width indicators
t	thickness

**Figure A.3 — Examples of probe positions for a set-through nozzle joint**



Table A.3 — Set-through nozzle joints

Testing level	Thickness of the parent material mm	Longitudinal discontinuities						Transverse discontinuities			
		Required number of					Total number of scans	Required number of		Total number of scans	Notes
		Beam angles	Probe positions	Scanning zone width	Probe positions	Scanning zone width		Beam angles	Probe positions		
		L-scans			N-scans			T-scans			
A	$8 \leq t < 15$	1	A	$1,25 p$	C	$c$	1	—	—	—	a
	$15 \leq t < 40$	1	A or F or D	$1,25 p$ $d$	C	$c$	2	—	—	—	a
B	$8 \leq t < 15$	1	A or D	$1,25 p$ $d + e$	C	$c$	2	1	(U and V) or (X and Y) or (W and Z)	2	b
	$15 \leq t < 40$	1	A or (D and E)	$1,25 p$ $d + e$	C	$c$	2 or 3	1	(U and V) or (X and Y) or (W and Z)	2	b
	$40 \leq t < 60$	1	(A or B) and (D and E)	$1,25 p$ $d + e$	C	$c$	4	1	(X and Y) and (W and Z)	4	b
	$60 \leq t \leq 100$	2 1	(A and B) and (D and E)	$0,5 p$ $d + e$	C	$c$	7	2	(X and Y) and (W and Z)	8	b
C	$8 \leq t < 15$	1	(A or B) and (D or E)	$1,25 p$ $d$ or $e$	C	$c$	3	1	(U and V) or (X and Y) and (W and Z)	2 or 4	b

	$15 \leq t \leq 40$	2	(A or B) and (D or E)	$0,5 p$ $d$ or $e$	C	$c$	5	2	(X and Y) and (W and Z)	8	<sup>b</sup>
	>40	2	(A or B) and (D or E)	$0,5 p$ $d + e$	C	$c$	9	2	(X and Y) and (W and Z)	8	<sup>b</sup>

<sup>a</sup> Not applicable.

<sup>b</sup> Shall be carried out by special agreement only.

NOTE 1 For symbols, see Figure A.3.

NOTE 2 L-scan: scan for longitudinal discontinuities using angle-beam probes; N-scan: scan using straight-beam probes; T-scan: scan for transverse discontinuities using angle-beam probes;  $p$  is the full skip distance.

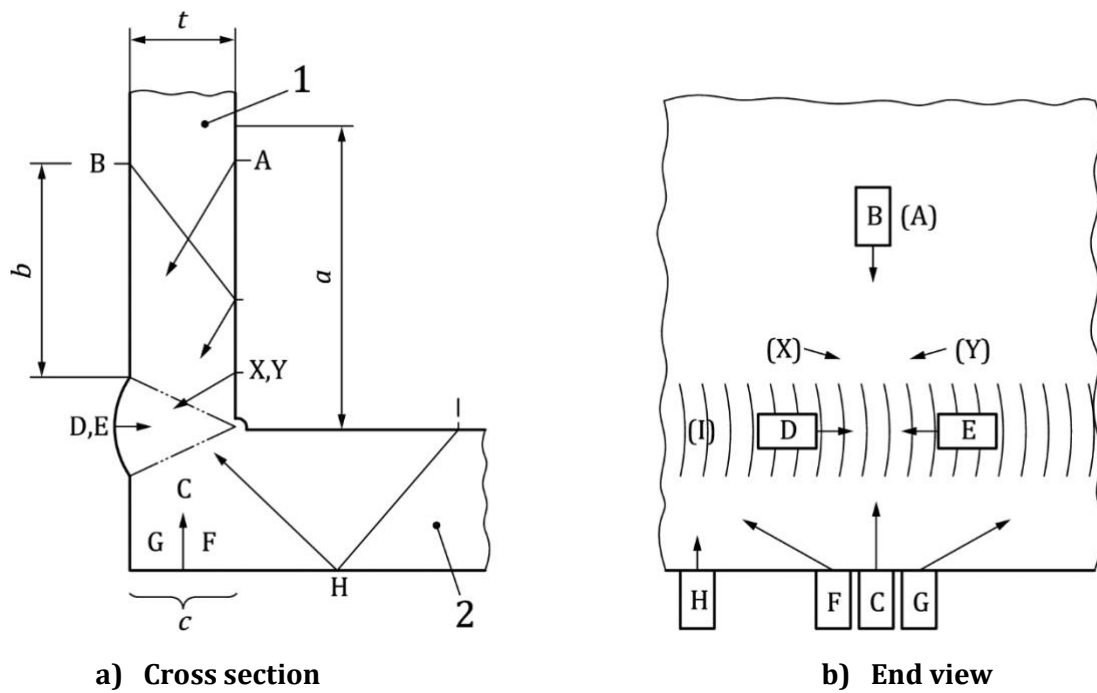

- Key**
- 1 component 1, nozzle
  - 2 component 2, shell
  - A, B, C, D, E, F, G, H, I, X, Y probe positions
  - a, b, c scanning zone width indicators
  - t thickness

**Figure A.4 — Examples of probe positions for a structural L-joint**



Table A.4 — Structural L-joints

Testing level	Thickness of the parent material mm	Longitudinal discontinuities						Transverse discontinuities			
		Required number of					Total number of scans	Required number of		Total number of scans	Notes
		Beam angles	Probe positions	Scanning zone width	Probe positions	Scanning zone width		Beam angles	Probe positions		
		L-scans			N-scans			T-scans			
A	$8 \leq t < 15$	1	A or B or H	$1,25 p$	C	$c$	1	—	—	—	a
	$15 \leq t \leq 40$	1	A or B or H	$1,25 p$	C	$c$	2	—	—	—	a
B	$8 \leq t < 15$	1	A or B or H	$1,25 p$	C	$c$	1	1	(F and G) or (X and Y)	2	b
	$15 \leq t < 40$	2	A or B or H	$1,25 p$	C	$c$	3	2	(F and G) or (X and Y)	4	b
	$40 \leq t \leq 100$	2	(H or A) and B	$0,75 p$	C	$c$	5	2	D and E	4	b,c
C	$8 \leq t < 15$	1	(H or A) and B	$1,25 p$	C	$c$	3	1	D and E	2	b,c
	$15 \leq t < 40$	2	(H or A) and B	$1,25 p$	C	$c$	5	1	D and E	2	b,c
	$40 \leq t \leq 100$	3	(H or A) and B	$1,25 p$	C	$c$	7	2	D and E	4	b,c
	$> 100$	3	(H or A) and B	$0,5 p$	C	$c$	7	2	D and E	4	b,c

<sup>a</sup> Not applicable.

<sup>b</sup> Shall be carried out by special agreement only.

<sup>c</sup> The surface of the weld cap shall comply with the requirements in Clause 9. This can require dressing of the weld cap.

NOTE 1 For symbols, see Figure A.4.

NOTE 2 L-scan: scan for longitudinal discontinuities using angle-beam probes; N-scan: scan using straight-beam probes; T-scan: scan for transverse discontinuities using angle-beam probes;  $p$  is the full skip distance.

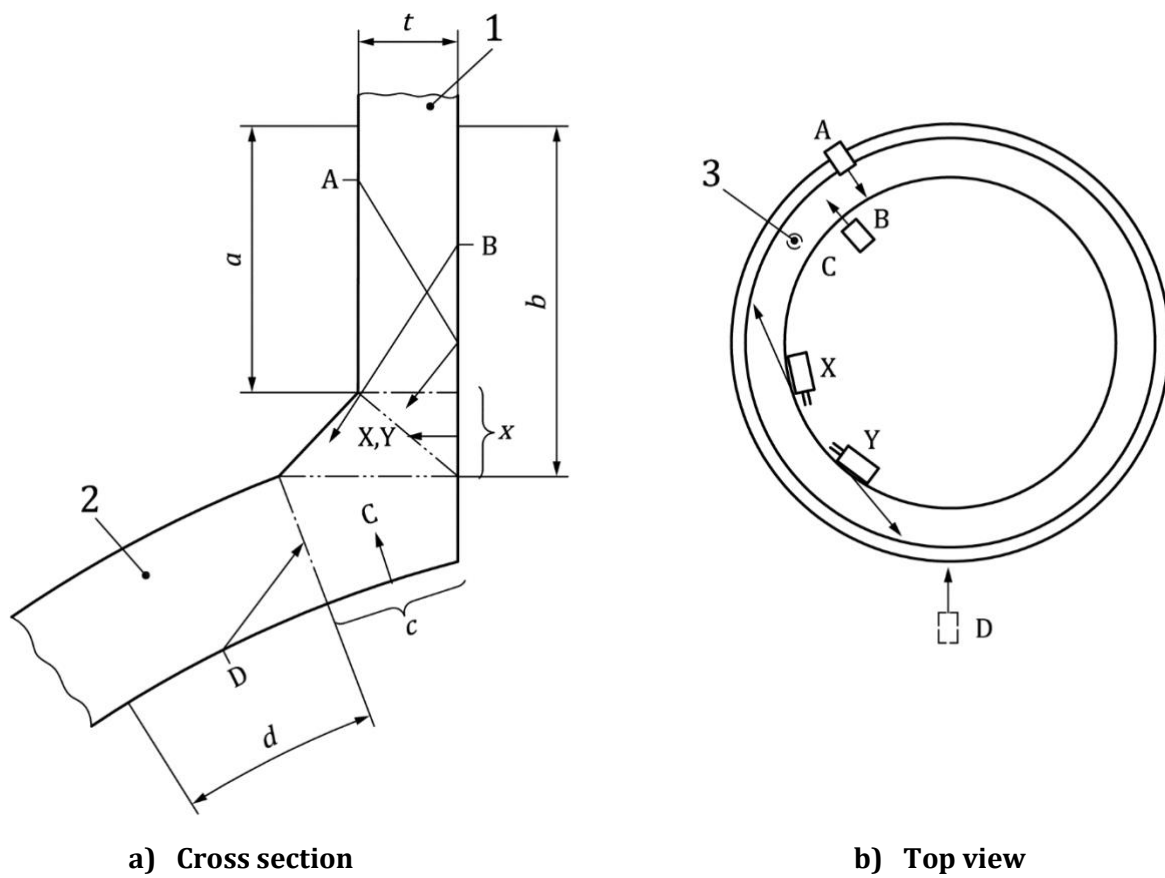

**Key**

1	component 1, nozzle
2	component 2, shell
3	straight-beam probe
A, B, C, D, X, Y	probe positions
$a, b, c, d, x$	scanning zone width indicators
$t$	thickness

**Figure A.5 — Examples of probe positions for a set-on nozzle joint**



Table A.5 — Set-on nozzle joints

Testing level	Thickness of the parent material mm	Longitudinal discontinuities						Transverse discontinuities			
		Required number of					Total number of scans	Required number of		Total number of scans	Notes
		Beam angles	Probe positions	Scanning zone width	Probe positions	Scanning zone width		Beam angles	Probe positions		
		L-scans			N-scans			T-scans			
A	$8 \leq t < 15$	1	A or B	$1,25 p$ $0,50 p$	—	—	1	—	—	—	a
	$15 \leq t \leq 40$	1	A or B	$1,25 p$ $0,50 p$	C	<i>c</i>	2	—	—	—	a
B	$8 \leq t < 15$	2	A or B	$1,25 p$ $0,50 p$	—	—	2	1	X and Y	2	b,c
	$15 \leq t < 40$	2	A or B	$1,25 p$ $0,50 p$	C	<i>c</i>	3	1	X and Y	2	b,c
	$40 \leq t < 60$	2	A and (B or D)	$1,25 p$ $0,50 p$	C	<i>c</i>	5	2	X and Y	4	b,c
	$60 \leq t \leq 100$	2	A and (B or D)	$1,25 p$ $0,5 p$	C	<i>c</i>	5	2	X and Y	4	b,c
C	$8 \leq t < 15$	3	A or B	$1,25 p$ $0,5 p$	C	<i>c</i>	4	1	X and Y	2	b,c
	$15 \leq t < 40$	3	A or B	$1,25 p$ $0,5 p$	C	<i>c</i>	4	1	X and Y	2	b,c
	$40 \leq t < 60$	3	A and B	$1,25 p$ $0,5 p$	C	<i>c</i>	7	2	X and Y	4	b,c

	$60 \leq t \leq 100$	3	A and B	$1,25 p$ $0,5 p$	C	<i>c</i>	7	2	X and Y	4	b,c
--	----------------------	---	---------	---------------------	---	----------	---	---	---------	---	-----

- a Not applicable.
- b Shall be carried out by special agreement only.
- c The surface of the weld cap shall comply with the requirements in Clause 9. This can require dressing of the weld cap.

NOTE 1 For symbols, see Figure A.5.

NOTE 2 L-scan: scan for longitudinal discontinuities using angle-beam probes; N-scan: scan using straight-beam probes; T-scan: scan for transverse discontinuities using angle-beam probes; *p* is the full skip distance.

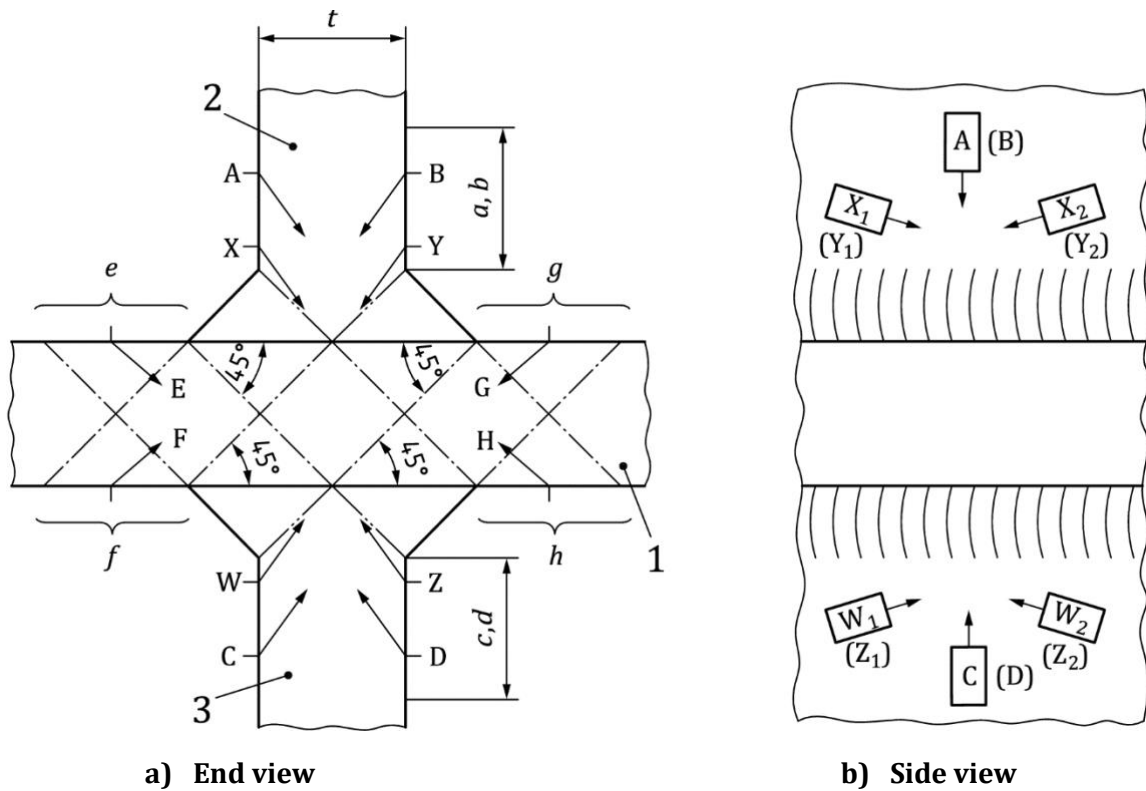

**Key**

- 1 component 1
- 2 component 2
- 3 component 3
- A, B, C, D, E, F, G, H, W, W<sub>1</sub>, W<sub>2</sub>, probe positions
- X, X<sub>1</sub>, X<sub>2</sub>, Y, Y<sub>1</sub>, Y<sub>2</sub>, Z, Z<sub>1</sub>, Z<sub>2</sub>
- a, b, c, d, e, f, g, h scanning zone width indicators
- t thickness

**Figure A.6 — Examples of probe positions for a cruciform joint**

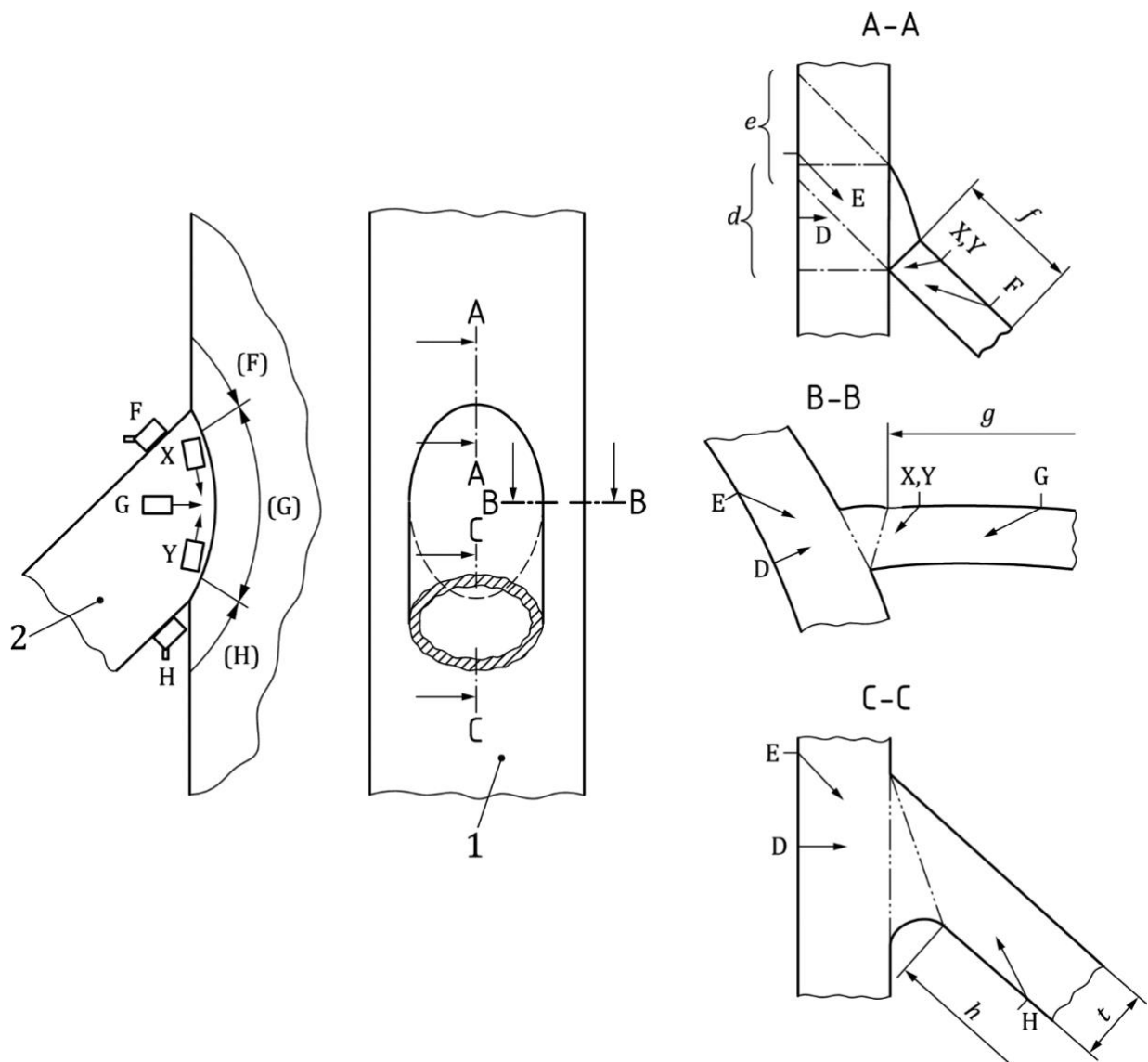

Table A.6 — Cruciform joints

Testing level	Thickness of the parent material mm	Longitudinal discontinuities					Transverse discontinuities			
		Required number of			Total number of scans	Notes	Required number of		Total number of scans	Notes
		Beam angles	Probe positions	Scanning zone width			Beam angles	Probe positions		
		L-scans			T-scans					
A	$8 \leq t < 15$	1	(A and C) or (B and D)	$1,25 p$	2	—	—	—	—	a
	$15 \leq t < 40$	1	A and B and C and D	$0,75 p$	4	c	—	—	—	a
	$40 \leq t \leq 100$	2	A and B and C and D	$0,75 p$	8	c	—	—	—	—
B	$8 \leq t < 15$	1	A and B and C and D	$1,25 p$	4	—	1	(X <sub>1</sub> and Y <sub>1</sub> and W <sub>1</sub> and Z <sub>1</sub> ) and (X <sub>2</sub> and Y <sub>2</sub> and W <sub>2</sub> and Z <sub>2</sub> )	8	b
	$15 \leq t < 40$	2	A and B and C and D	$0,75 p$	8	c	1	(X <sub>1</sub> and Y <sub>1</sub> and W <sub>1</sub> and Z <sub>1</sub> ) and (X <sub>2</sub> and Y <sub>2</sub> and W <sub>2</sub> and Z <sub>2</sub> )	8	b
	$40 \leq t \leq 100$	2 1	(A and B and C and D) and (E and F and G and H)	$0,75 p$ $e - h$	12	d d	2	(X <sub>1</sub> and Y <sub>1</sub> and W <sub>1</sub> and Z <sub>1</sub> ) and (X <sub>2</sub> and Y <sub>2</sub> and W <sub>2</sub> and Z <sub>2</sub> )	16	b
C	$40 \leq t \leq 100$	2 1	(A and B) and (C and D) and (E and F) and tandem (A or B) and (C or D)	$0,75 p$ $e - h$	14	—	2	(X <sub>1</sub> and Y <sub>1</sub> and W <sub>1</sub> and Z <sub>1</sub> ) and (X <sub>2</sub> and Y <sub>2</sub>	16	b

			and (G and H)						and $W_2$ and $Z_2$ )		
<p>a Not applicable.</p> <p>b Shall be carried out by special agreement only.</p> <p>c If a more sensitive level is required, a tandem technique shall be applied.</p> <p>d If a more sensitive level is required, a tandem technique shall be applied. In this case, E and F and G and H shall be omitted.</p> <p>NOTE 1 For symbols, see Figure A.6.</p> <p>NOTE 2 L-scan: scan for longitudinal discontinuities using angle-beam probes; N-scan: scan using straight-beam probes; T-scan: scan for transverse discontinuities using angle-beam probes; <math>p</math> is the full skip distance.</p>											





**Key**

- 1 component 1, main pipe
- 2 component 2, branch pipe
- A, B, C, D, E, F, G, H, X, Y probe positions
- d, e, f, g, h* scanning zone width indicators
- t* thickness

**Figure A.7 — Examples of probe positions for a node joint in tubular structure**



Table A.7 — Node joints in tubular structures

Testing level	Thickness of the parent material mm	Longitudinal discontinuities						Transverse discontinuities			
		Required number of					Total number of scans	Required number of		Total number of scans	Notes
		Beam angles	Probe positions	Scanning zone width	Probe positions	Scanning zone width		Beam angles	Probe positions		
		L-scans			N-scans			T-scans			
A	$8 \leq t < 15$	2	F and G and H	$1,25 p$	—	—	6	—	—	—	a,b
	$15 \leq t < 40$	3	F and G and H	$1,25 p$	—	—	9	—	—	—	a,b
	$40 \leq t \leq 100$	3	F and G and H	$1,25 p$	—	—	9	—	—	—	a,b
B	$8 \leq t < 15$	2	F and G and H	$1,25 p$ $0,50 p$	D	$d$	7	1	X and Y	2	a,c
	$15 \leq t < 40$	3	F and G and H	$1,25 p$ $0,50 p$	D	$d$	10	2	X and Y	4	a,c
	$40 \leq t \leq 100$	3 1	(F and G and H) and E	$1,25 p$ $e$	D	$d$	11	2	X and Y	4	a,c
C						—					

<sup>a</sup> Node joint testing shall usually be level D, requiring special agreement.

<sup>b</sup> Not applicable.

<sup>c</sup> If the bore of component 1 is not accessible (probe positions D and E), testing level B cannot be achieved.

NOTE 1 For symbols, see Figure A.7.

NOTE 2 L-scan: scan for longitudinal discontinuities using angle-beam probes; N-scan: scan using straight-beam probes; T-scan: scan for transverse discontinuities using angle-beam probes;  $p$  is the full skip distance.



## Bibliography

- [1] ISO 5817, *Welding — Fusion-welded joints in steel, nickel, titanium and their alloys (beam welding excluded) — Quality levels for imperfections*